

NOZZLE TYPE "D" WITH SCREWED TYP Ø 30
BUSE TYPE "D" avec POINTE VISSÉE Ø 30

DÜSENSPITZENTYPE "D" MIT AUSWECHSELBARER DÜSENSPITZE Ø 30

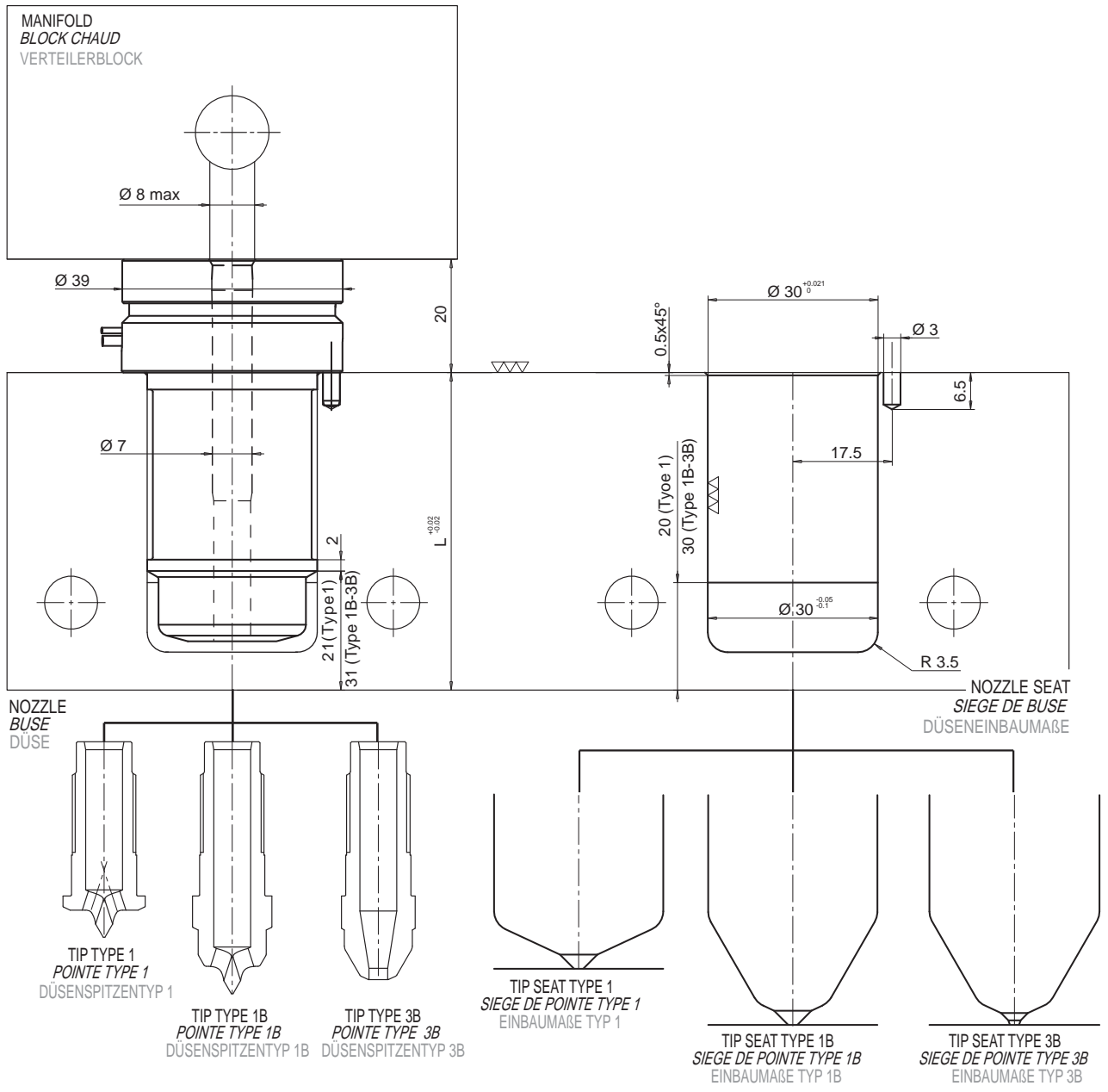

HEATER AND THERMOCOUPLE / RESISTANCE THERMOCOUPLE
HEIZUNG UND THERMOFÜHLER

Single heater <i>Une seule résistance</i> Einzelheizung	White / Red - White <i>Blanche / Rouge - Blanche</i> Weiss / Rot - Weiss	230 V
---	--	-------

Grounded thermocouple J type calibration <i>Thermocouple à la masse calibré type J</i> Geerdeter Thermofühler Typ J	Red / Rouge / Rot	TC+
	Blue / Bleu / Blau	TC-

Example of order
Exemple de désignation
Bestellbeispiel:

Nozzle Buse Düse	Ø D	Length L Longueur L Länge L	Tip type Type de pointe Düsenstizentyp
D N	3 0	0 8 6	- - 1

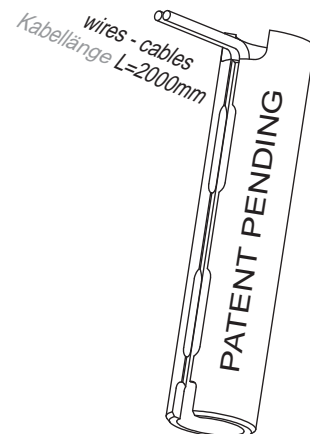

Tip for direct injection - Pointe pour l'injection directe - Düsen Spitze für direkte Anspritzung

TYPE-TYP 1 (Ref. -1)

Code
E17098

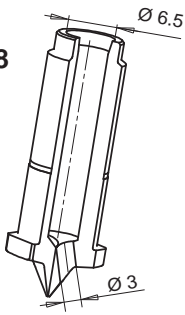

Tip seat - Siege de pointe - Einbaumaße

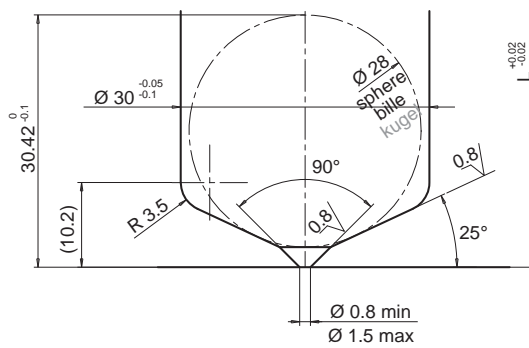

Tip seat - Siege de pointe - Einbaumaße

L	46	56	66	76	86	96	106	116	126	136	146	156	166	176	186	196	206
---	----	----	----	----	----	----	-----	-----	-----	-----	-----	-----	-----	-----	-----	-----	-----

COLOUR CHANGE BUSHING
Available upon request

DOUILLE CHANGE COULEUR
Disponible sur demande

VORKAMMERBUCHSE FÜR FARBWECHSEL
Vorhanden auf Anfrage

Code
E17105

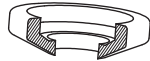

Variation on the seat with colour change bushing
 Tolérance du siège pour montage avec douille change-couleur
 Einbaumaße der Vorkammerbuchse für Farbwechsel



TYPE-TYP 1B (Ref. -1B)

Code
E17099

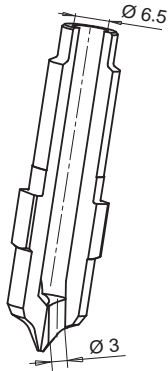

Tip seat - Siege de pointe - Einbaumaße

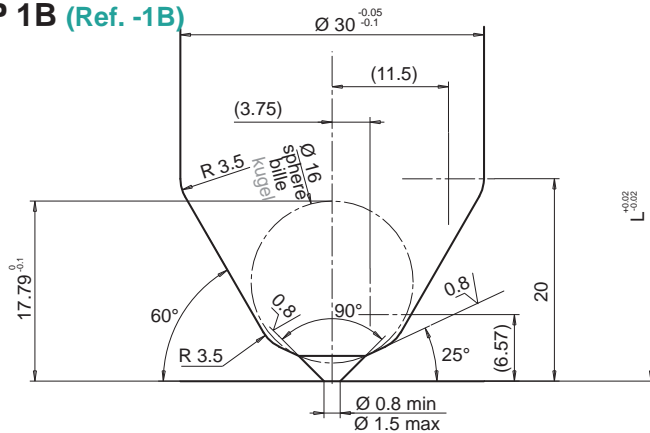

Tip seat - Siege de pointe - Einbaumaße

L	56	66	76	86	96	106	116	126	136	146	156	166	176	186	196	206	216
---	----	----	----	----	----	-----	-----	-----	-----	-----	-----	-----	-----	-----	-----	-----	-----

TYPE-TYP 3B (Ref. -3B)

Code
E17100

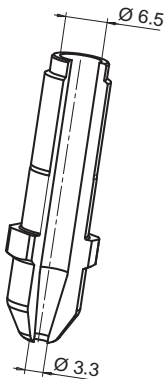

Tip seat - Siege de pointe - Einbaumaße

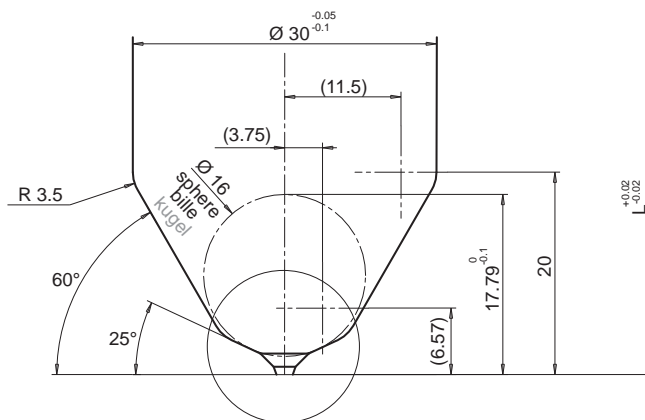

Tip seat - Siege de pointe - Einbaumaße

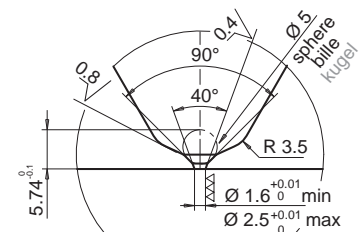

CONICAL - CONIQUE- KONISCH

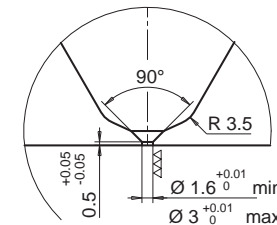

CYLINDRICAL - CYLINDRIQUE
ZYLINDRISCH

L	56	66	76	86	96	106	116	126	136	146	156	166	176	186	196	206	216
---	----	----	----	----	----	-----	-----	-----	-----	-----	-----	-----	-----	-----	-----	-----	-----

DN Ø30

TIP TYPE - TYPE DE POINTE- DÜSENSPITZENTYP

HERMOPLAY®
HERMOPLAY®

NEW

FOR NOZZLE TYPE 3B Ø30- POUR BUSES TYPE 3B Ø 30- FÜR DÜSENTYP 3B Ø 30

HERMOPLAY®
HERMOPLAY

10/2007

BOTH PNEUMATIC AND HYDRAULIC SHUT OFF VALVE
GROUPE OBTURATION SOIT HYDRAULIQUE QUE PNEUMATIQUE
NADELVERSCHLÜßSYSTEM, GEEIGNET FÜR PNEUMATISCHE - UND HYDRAULISCHE BETÄTIGUNG

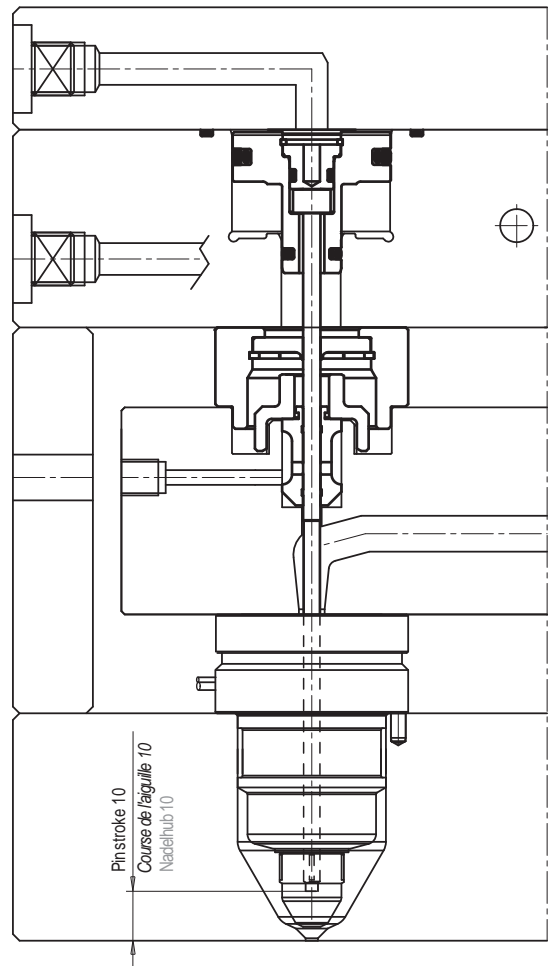
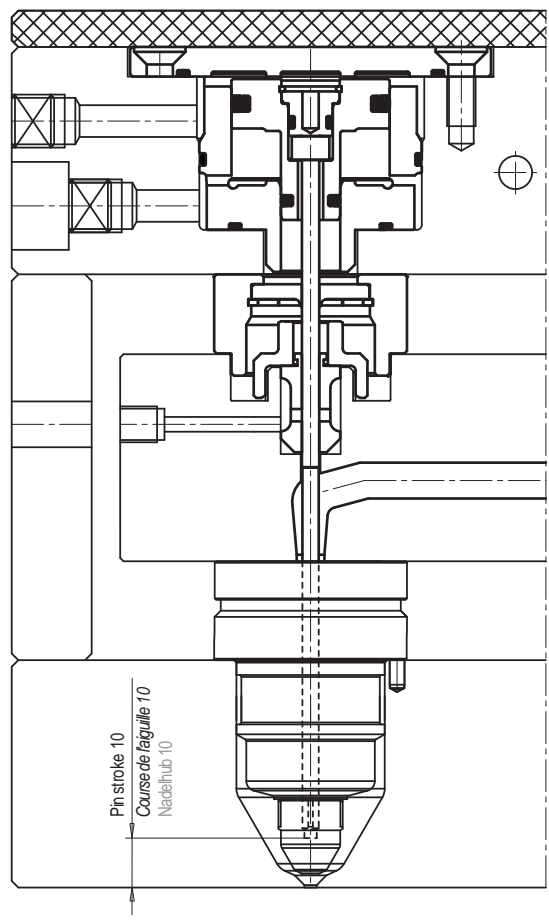
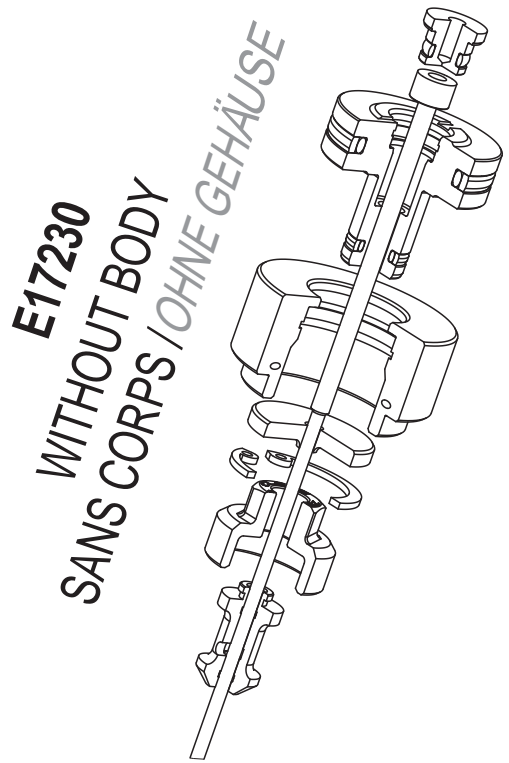
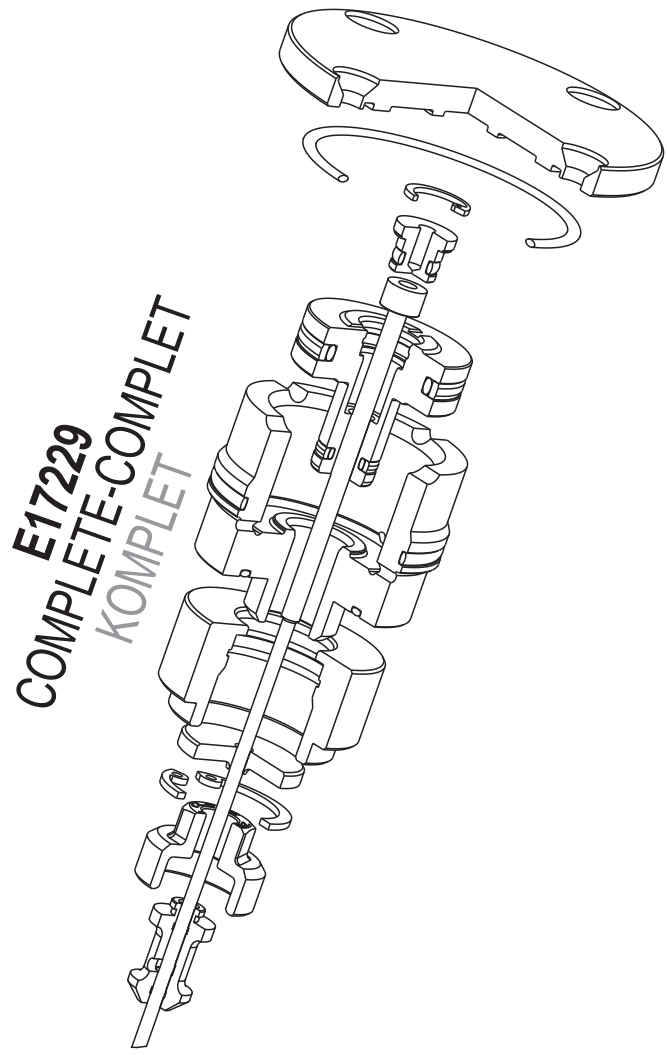

PNEUMATIC SHUT OFF VALVE
GROUPE OBTURATION PNEUMATIQUE

NADELVERSCHLÜßSYSTEM, GEEIGNET FÜR PNEUMATISCHE BETÄTIGUNG

NEW

E17235

STANDARD NEEDLE
AIGUILLE LIBRE - BEWEGLICHE NADEL

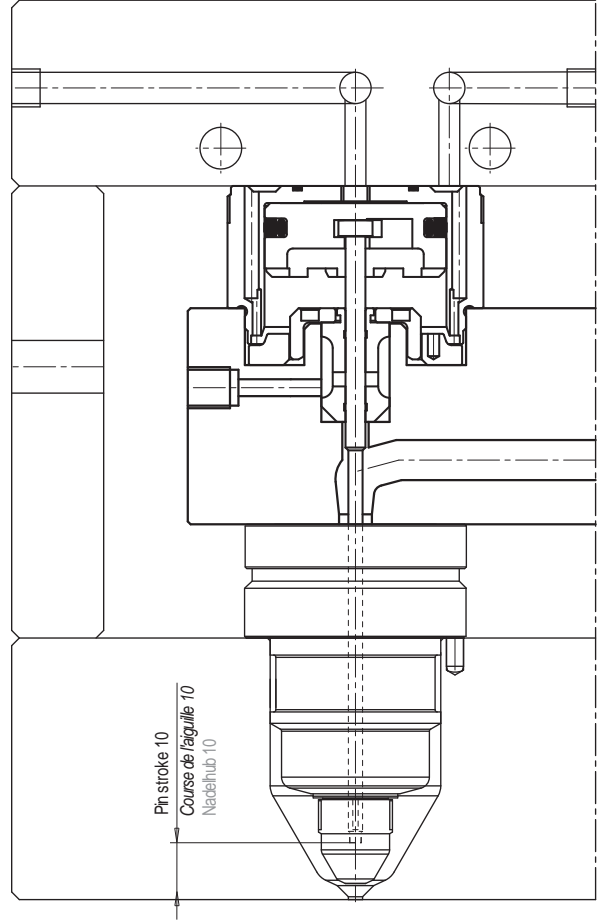
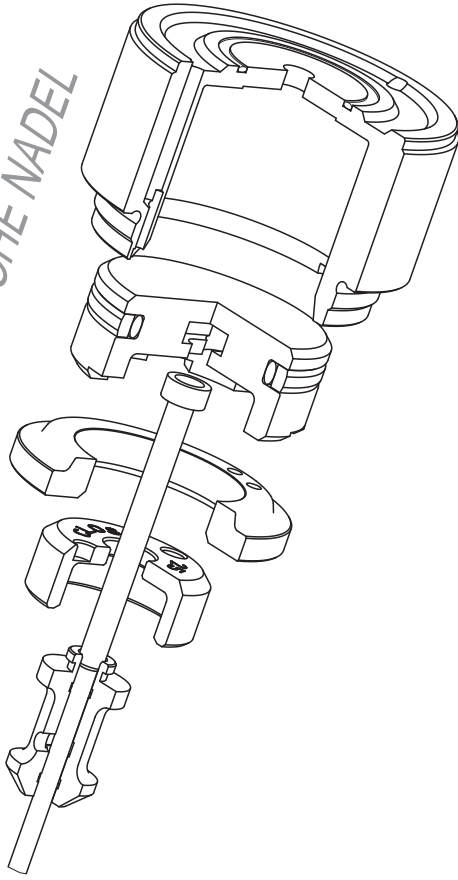

E17236

ORIENTED NEEDLE - AIGUILLE ORIENTÉE
ORIENTIERTE NADEL

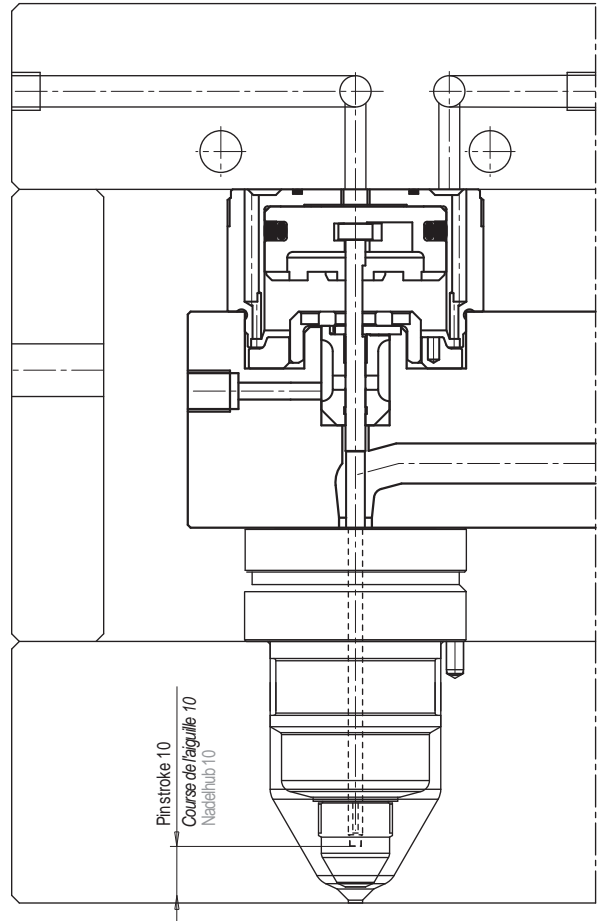
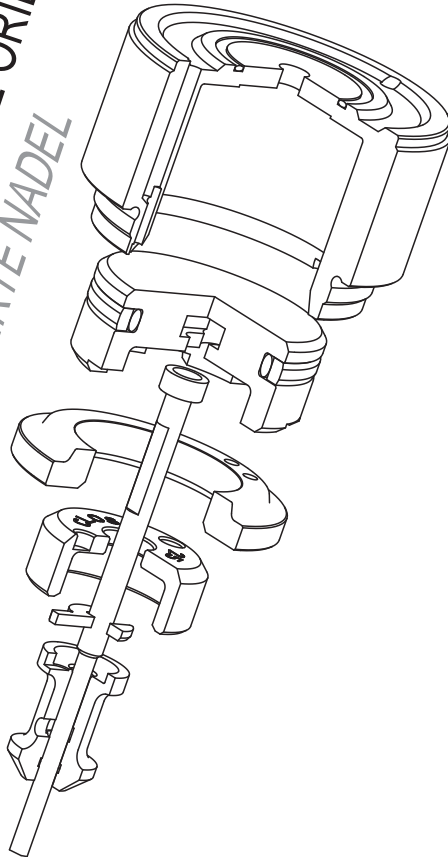

10/2007

THERMOPLAY®
THERMOPLASTIC
PIPE

FOR NOZZLE TYPE 3B Ø30- POUR BUSES TYPE 3B Ø 30- FÜR DÜSENTYP 3B Ø 30