

• SINGLE NOZZLE / EINZELDÜSE

Single nozzle code Einzeldüse	① L	Heater code Heizung	Watt	Thermocouple / Thermofühler ③	
				grounded - geerdet .. - JG	insulated - isoliert .. - JU
DN618046B-1..	46	E16853	160	E16871	E17865
DN618056B-1..	56	E16854	180		
DN618066B-1..	66	E16855	180		
DN618076B-1..	76	E16856	180		
DN618086B-1..	86	E16857	200		
DN618096B-1..	96	E16858	200	E16872	E17866
DN618106B-1..	106	E16859	200		
DN618116B-1..	116	E16860	200		
DN618126B-1..	126	E16861	200		
DN618136B-1..	136	E16862	230		
DN618146B-1..	146	E16863	230	E16873	E17867
DN618156B-1..	156	E16864	230		
DN618166B-1..	166	E16865	230		
DN618176B-1..	176	E16866	230		
DN618186B-1..	186	E16867	250		
DN618196B-1..	196	E16868	250	E16874	E17868
DN618206B-1..	206	E16869	250		
DN618216B-1..	216	E16870	250		

Ordering code example: / Bestellbeispiel:

DN 6 18 146 B-1-25- JG/S004

- ① Length - Länge
- ② Tip type 1B - Ø tip 0.25
Düsen Spitze 1B - Ø Düsen Spitze 0,25
- ③ Grounded thermocouple
Geerdeter Thermofühler
- ④ 40 mm radius injection bush
Anlage radius R= 40 mm

Suffix for injection bushing type

Suffix / Code ④	R	WxP
../S001	0	
../S002	1/2"	
../S003	19.5	
../S004	40	
../S005		Ø14x21
../S006		Ø16x21

If non specified, the -25 tip and grounded thermocouple are supplied
Wenn nicht spezifiziert, werden die Spitzen -25 und der geerdete Thermofühler geliefert

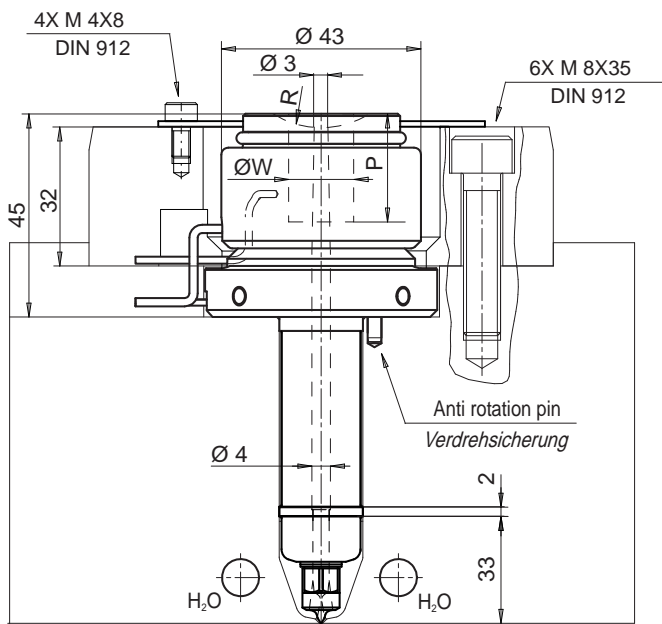

NOZZLE
DÜSE

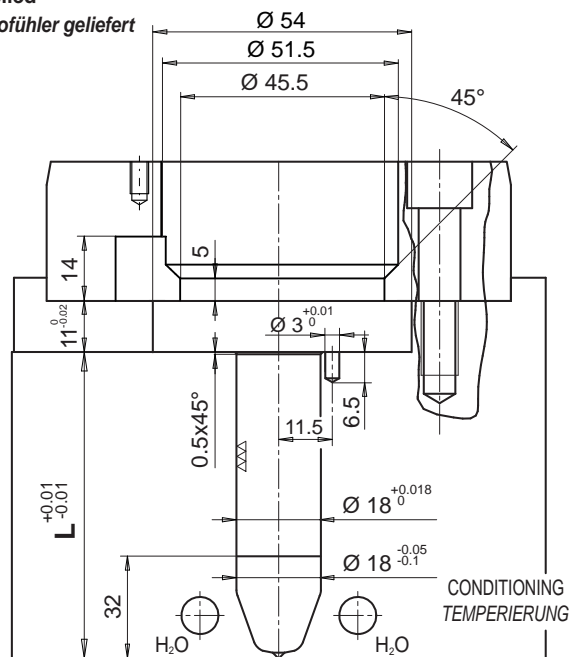

NOZZLE SEAT
DÜSENEINBAUMASSE

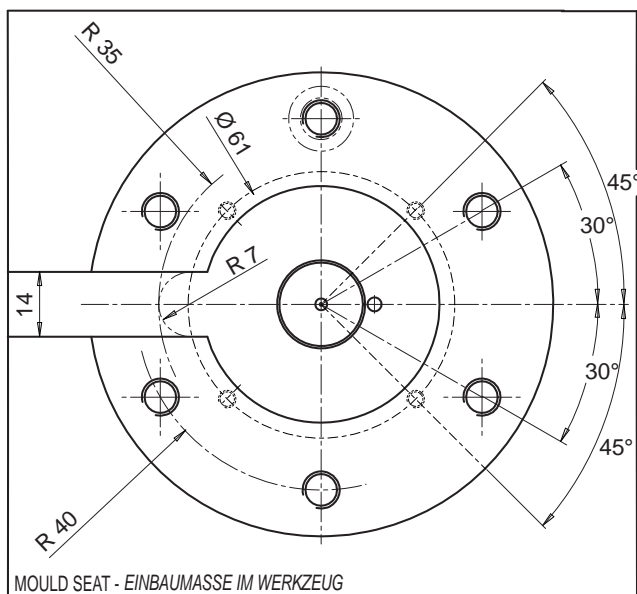

MOULD SEAT - EINBAUMASSE IM WERKZEUG

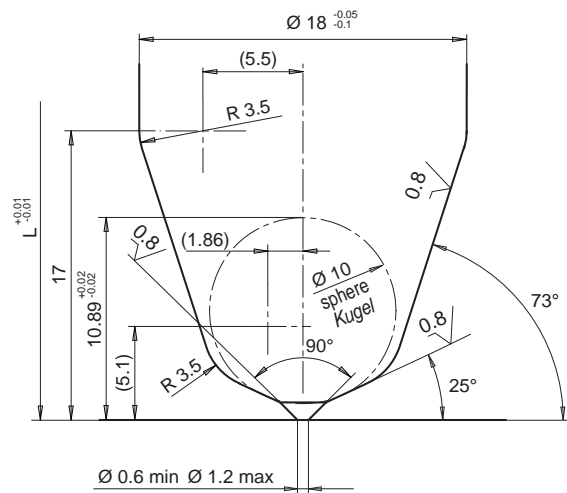

Gate diameter is approximate and could vary depending on injected volume and part wall thickness.

Der Durchmesser steht in Abhängigkeit des Volumens und der Materialstärke des Bauteils.

• SPARE PARTS AND ACCESSORIES / ERSATZTEILE UND ZUBEHÖR

TIP / DÜSENSPITZE

Code	Suffix
E17840	.. 1-25

Injection diameter with tip Ø 0,25 mm
Anspritzdurchmesser mit Spitze Ø 0,25 mm

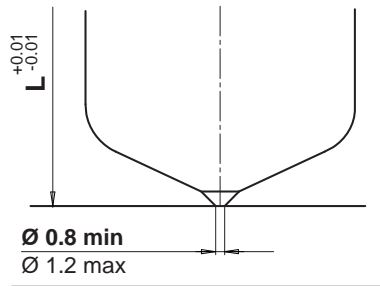
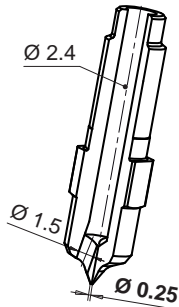

HEATER AND THERMOCOUPLE
HEIZUNG UND THERMOFÜHLER

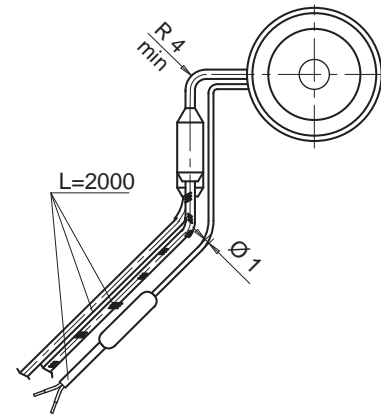

Code	Suffix
E17837	.. 1-10

Injection diameter with tip Ø 0,1 mm
Anspritzdurchmesser mit Spitze Ø 0,1 mm

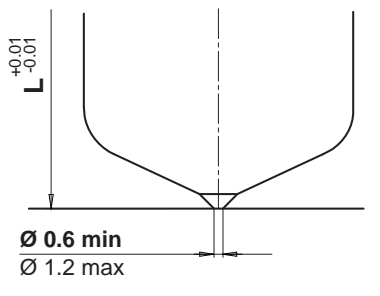
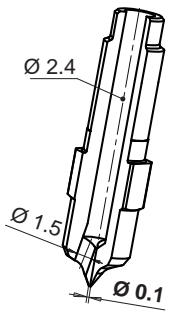

Suffix Zusatzcode	Description / Beschreibung
.. - JG	Grounded thermocouple with J type calibration Geerdeter Thermofühler Typ J.
.. - JU	Insulated thermocouple with J type calibration Isolierter Thermofühler Typ J

HEATER / HEIZUNG	
White / Red-White weiss / Rot-Weiss	230 V
THERMOCOUPLE / THERMOFÜHLER	
Red / Rot	TC+
Blue / Blau	TC-

HEAD HEATER / DÜSENKOPFHEIZUNG

Code	Description / Beschreibung
E09040	Head heater 400 Watt Düsenkopfheizung 400 Watt
cables Kabel	Brown/Brown black Braun/Braun-schwarz
	230 V

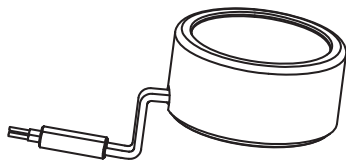

HEAD THERMOCOUPLE / THERMOFÜHLER FÜR KOPF

Code	Description / Beschreibung
E07033 ..-JG	Grounded thermocouple with J type calibration Geerdeter Thermofühler Typ J.
E16035 ..-JU	Insulated thermocouple with J type calibration Isolierter Thermofühler Typ J
cables Kabel	Red / Rot
	TC +
	Blue / Blau
	TC -

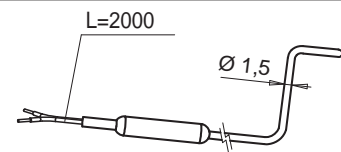

HEAD RING / JUSTIERRING

Code	Description / Beschreibung
E09062	Seal ring for head heater Justierring für Düsenkopfheizung



HEAD RING / JUSTIERRING

Code	Description / Beschreibung
E17992	Seal ring for head Justierring für Kopf

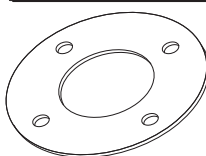

Seal ring is supplied with single nozzles
Wird mit der Einzeldüse geliefert

DISASSEMBLY TOOL FOR TIP NOZZLES
DEMONTAGWERKZEUG FÜR DÜSENSPITZE

Available upon request / Auf Anfrage

Code	Description / Beschreibung
E17818	Socket Ø 8 Mehrkantschlüssel Ø 8 DIN 3124 UNI-ISO 2725

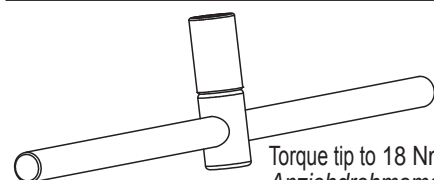

Torque tip to 18 Nm
Anziehdrehmoment 18 Nm