

• UGELLO PER STAMPI MULTICAVITÀ / BUSE POUR MOULES MULTI-EMPREINTES

Codice ugello Code buse	L	Codice resistenza Code résistance	Watt	Termocoppia Thermocouple
F46076-A-2DSLA	76	E15521	480	E05505-F46
F46086-A-2DSLA	86	E15522	480	
F46096-A-2DSLA	96	E15147	540	
F46106-A-2DSLA	106	E15148	540	
F46116-A-2DSLA	116	E15149	540	
F46126-A-2DSLA	126	E15150	580	E15206-F46
F46136-A-2DSLA	136	E15151	580	
F46146-A-2DSLA	146	E15152	580	
F46156-A-2DSLA	156	E15153	640	
F46166-A-2DSLA	166	E15154	640	
F46176-A-2DSLA	176	E15155	640	E15223-F46
F46186-A-2DSLA	186	E15156	720	
F46196-A-2DSLA	196	E15157	720	
F46206-A-2DSLA	206	E15158	720	
F46216-A-2DSLA	216	E15159	760	
F46226-A-2DSLA	226	E15160	760	E15224-F46
F46236-A-2DSLA	236	E15161	760	
F46246-A-2DSLA	246	E15162	790	
F46256-A-2DSLA	256	E15163	790	
F46266-A-2DSLA	266	E15164	790	
F46276-A-2DSLA	276	E15165	810	E15225-F46
F46286-A-2DSLA	286	E15166	810	
F46296-A-2DSLA	296	E15167	810	
F46306-A-2DSLA	306	E15168	840	
F46316-A-2DSLA	316	E15169	840	
F46326-A-2DSLA	326	E15170	840	E15226-F46
F46336-A-2DSLA	336	E15171	880	
F46346-A-2DSLA	346	E15172	880	
F46356-A-2DSLA	356	E15173	880	

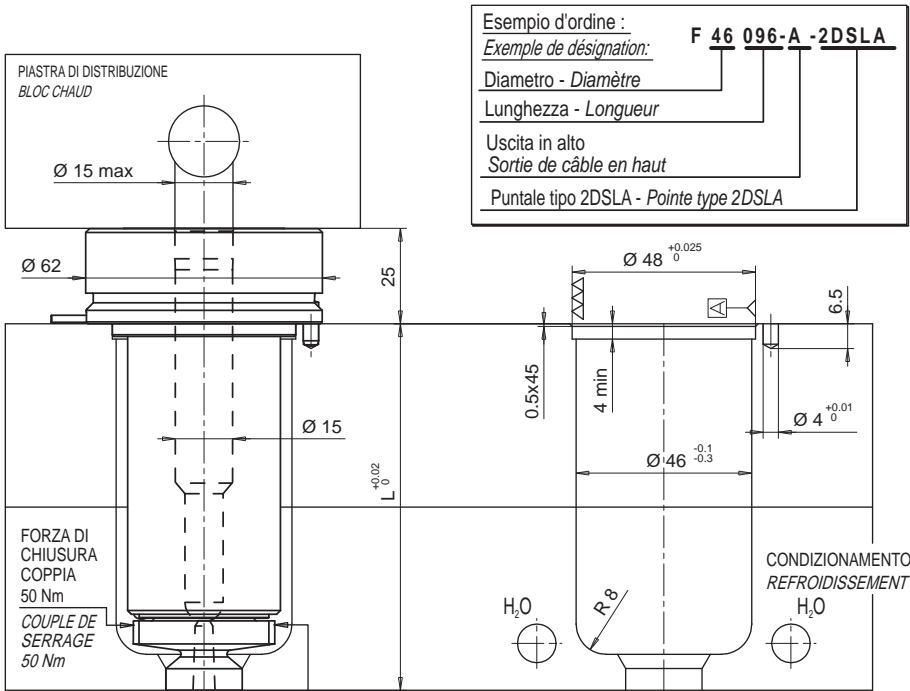
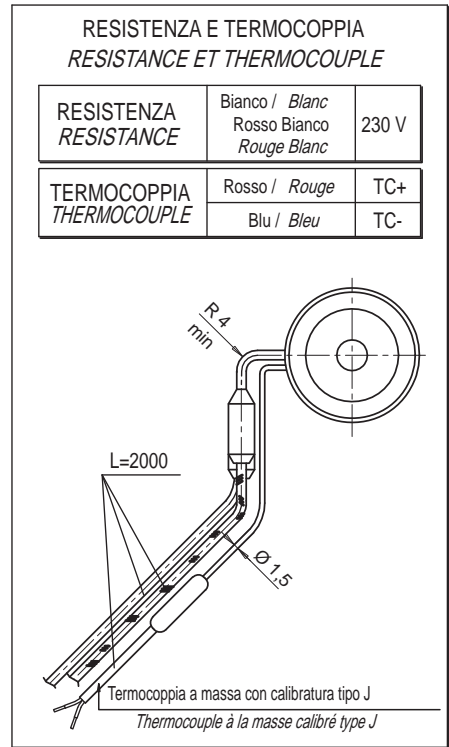
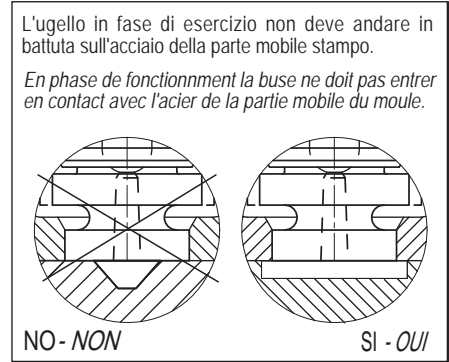
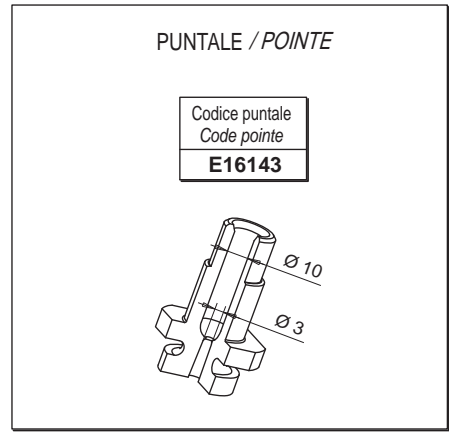

Esempio d'ordine : **F 46 096-A -2DSLA**

Exemple de désignation:

Diametro - Diamètre

Lunghezza - Longueur

Uscita in alto
Sortie de câble en haut

Puntale tipo 2DSLA - Pointe type 2DSLA

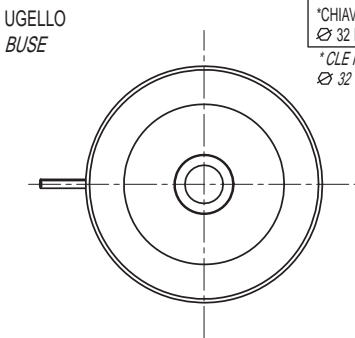

*CHIAVE POLIGONALE E16185
Ø 32 DIN 3120 UNI-ISO 1174
*CLE POLYгонаLE E16185
Ø 32 DIN 3120 UNI-ISO 1174

