

• SINGLE NOZZLE / EINZELDÜSE

Code nozzle Düse	L	Heater code Heizung	Watt	Thermocouple Thermofühler
F624056-1B/S0....	56	E09610	200	E05302-F24
F624066-1B/S0....	66	E09428	200	
F624076-1B/S0....	76	E09431	200	
F624086-1B/S0....	86	E09433	200	
F624096-1B/S0....	96	E09436	200	
F624106-1B/S0....	106	E09438	250	
F624116-1B/S0....	116	E09441	250	E05504-F24
F624126-1B/S0....	126	E09443	250	
F624136-1B/S0....	136	E09446	250	
F624146-1B/S0....	146	E09448	270	
F624156-1B/S0....	156	E09451	270	E05917-F24
F624166-1B/S0....	166	E09453	300	
F624176-1B/S0....	176	E09456	300	
F624186-1B/S0....	186	E09458	350	
F624196-1B/S0....	196	E09461	350	E05913-F24
F624206-1B/S0....	206	E09463	350	
F624216-1B/S0....	216	E09465	350	

Code	R	WxP
../S001	0	
../S002	1/2"	
../S003	19.5	
../S004	40	
../S005		Ø14x21
../S006		Ø16x21

TIP / DÜSENSPITZE

Tip code  
Düsen Spitze  
**E09479**

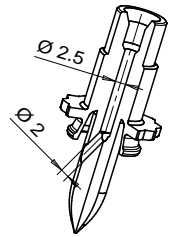

Example of order: **F 6 24 146-1B/S004**  
 Bestellbeispiel:  
 Singlenozzle - Einzeldüse  
 Nozzle - Düse  
 Length - Länge  
 Tip type - Düsen Spitze  
 40 mm spheric radius injection bushing  
 Angießbuchse R 40 mm

Suggested for easy flow materials not stiffened such as PP, PE and PS. For other material types consult Thermoplay's technical support. It is not advisable for moulding with materials stiffened with abrasive fibres.  
 Empfohlen für die Materialien PP-PE und PS unverstärkt. Für andere Materialien wenden Sie sich an den technischen Kundendienst Thermoplay. (Nicht empfohlen für das Formpressen von gefüllten, verstärkten Materialien).

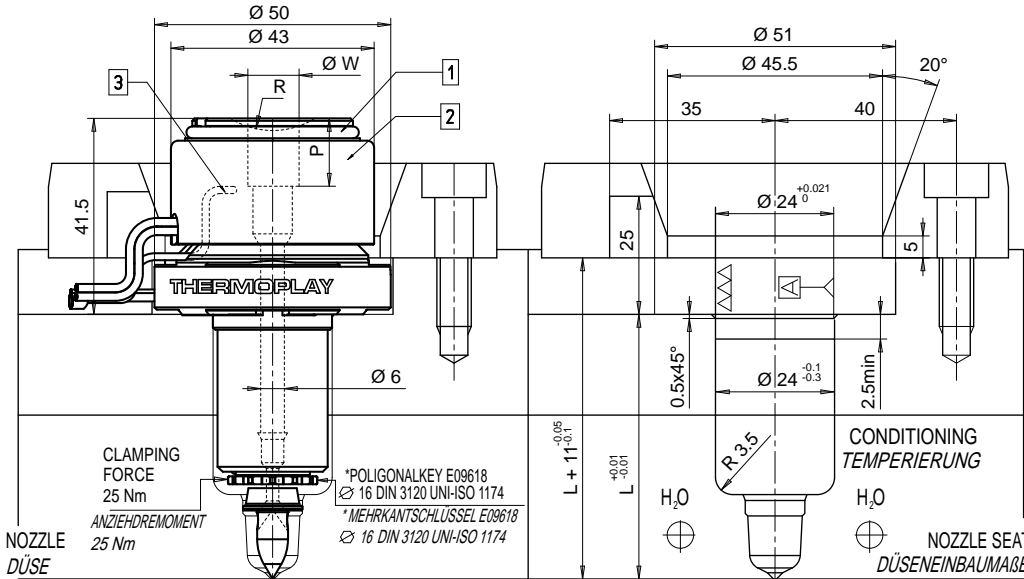

**HEATER AND THERMOCOUPLE  
HEIZUNG UND THERMOFÜHLER**

HEATER HEIZUNG	White / Weiss Red White Rot Weiss	230 V
THERMOCOUPLE THERMOFÜHLER	Red / Rot Blue / Blau	TC+ TC-

Grounded thermocouple with J type calibration  
 Die Masse des Thermofuehlers ist zusammen mit dem Type J.

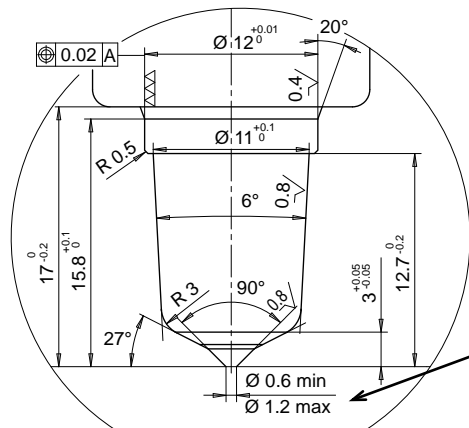

Injection diameter is approximate and can change depending on the injected volume of thermoplastic material and on the wall thickness part. Der Durchmesser der Einspritzung ist angegeben und kann durch das Volumen der Injection des thermoplastischen Materials und der Stärke des Formteils variieren.

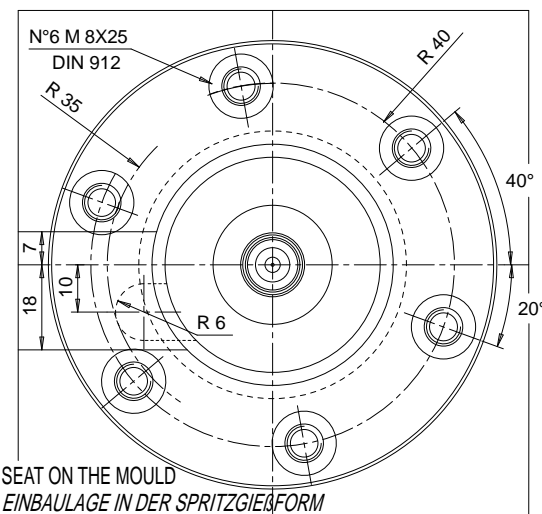

**SPARE PARTS / ERSATZTEILE**

1 SEAL RING FOR HEATER BAND JUSTIERRING FÜR HEIZBAND Code E09062	2 HEAD HEATER 230 V DÜSENKOPFHEIZUNG 230 V Code E09040 400 W Brown / Braun Brown-Black Braun-Schwarz 230 V	3 HEAD THERMOCOUPLE THERMOFÜHLER KOPF Code E07033 Red / Rot + Blue / Blau -
--	---	---