

• SINGLE NOZZLE / EINZELDÜSE

Code nozzle / Düse		L	Heater code Heizung	Watt	Thermocouple / Thermofühler	
with tip / mit Düsenspitze E09820	with tip / mit Düsenspitze E09821				grounded geerdet	insulated isoliert
FLH624046-2/S0...	FLH624046-2MD/S0...	46	E16657	410	E05302-F24	E16027-F24
FLH624056-2/S0...	FLH624056-2MD/S0...	56	E16658	425		
FLH624066-2/S0...	FLH624066-2MD/S0...	66	E16659	425		
FLH624076-2/S0...	FLH624076-2MD/S0...	76	E16660	465		
FLH624086-2/S0...	FLH624086-2MD/S0...	86	E16661	465	E05504-F24	E16029-F24
FLH624096-2/S0...	FLH624096-2MD/S0...	96	E16662	510		
FLH624106-2/S0...	FLH624106-2MD/S0...	106	E16663	510		
FLH624116-2/S0...	FLH624116-2MD/S0...	116	E16664	550		
FLH624126-2/S0...	FLH624126-2MD/S0...	126	E16665	550	E05917-F24	E16030-F24
FLH624136-2/S0...	FLH624136-2MD/S0...	136	E16666	580		
FLH624146-2/S0...	FLH624146-2MD/S0...	146	E16667	580		
FLH624156-2/S0...	FLH624156-2MD/S0...	156	E16668	630		
FLH624166-2/S0...	FLH624166-2MD/S0...	166	E16669	630	E05913-F24	E16031-F24
FLH624176-2/S0...	FLH624176-2MD/S0...	176	E16670	660		
FLH624186-2/S0...	FLH624186-2MD/S0...	186	E16671	660		
FLH624196-2/S0...	FLH624196-2MD/S0...	196	E16672	700		
FLH624206-2/S0...	FLH624206-2MD/S0...	206	E16673	700		

Code	R	Ø u
../S001	0	4.1
../S002	1/2"	6.2
../S003	19.5	6.1
../S004	40	4.9

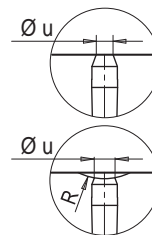

Ordering code example: **FLH6 24 206- 2 / S004 - JG**

Bestellbeispiel:
 Single nozzle - Einzeldüse
 Nozzle - Düse Ø
 Length - Länge
 Tip type - Düsenspitze
 40 mm radius injection bush
 Anlage radius R= 40 mm
 Grounded thermocouple - Thermofühler geerdet

If non specified, grounded thermocouple is supplied.
 Wenn nicht spezifiziert, wird der geerdete Thermofühler geliefert

TIP / DÜSENSPITZE		Code tip Düsenspitze
2	For materials not stiffened Für ungefüllte, unverstärkte Materialien	E09820
2MD	For reinforced materials Für gefüllte, verstärkte Materialien	E09821

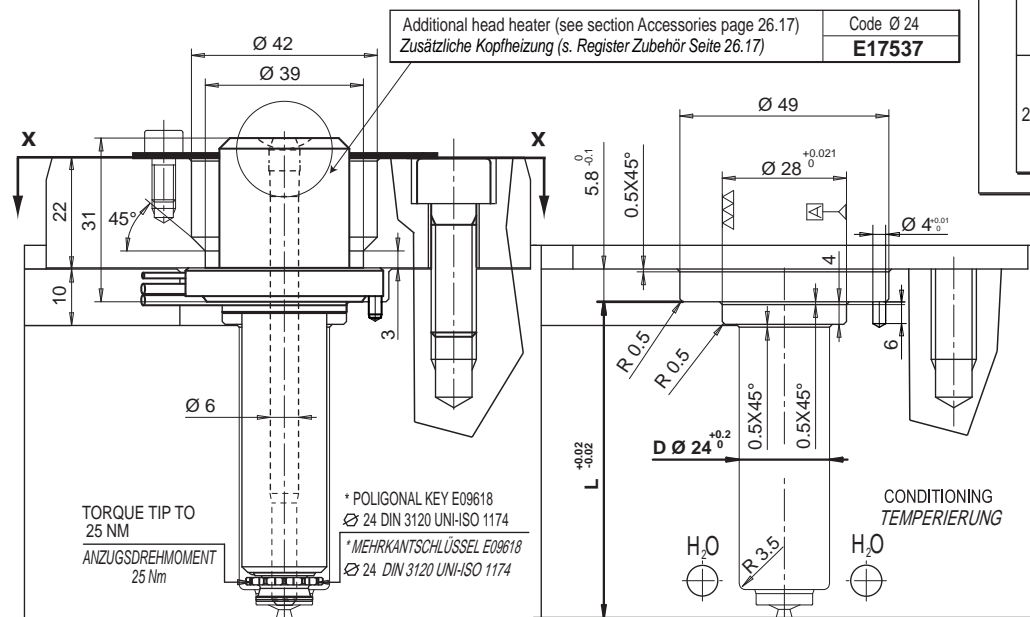
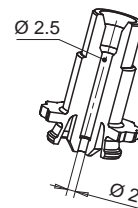

HEATER AND THERMOCOUPLE
 HEIZUNG UND THERMOFÜHLER

HEATER HEIZUNG	White / Weiss Red White Rot Weiss	230 V
THERMOCOUPLE THERMOFÜHLER	Red / Rot Blue / Blau	TC+ TC-

Suffix Zusatzcode	Description / Beschreibung
.. - JG	Grounded thermocouple with J type calibration Geerdeter Thermofühler Typ J.
.. - JU	Insulated thermocouple with J type calibration Isolierter Thermofühler Typ J

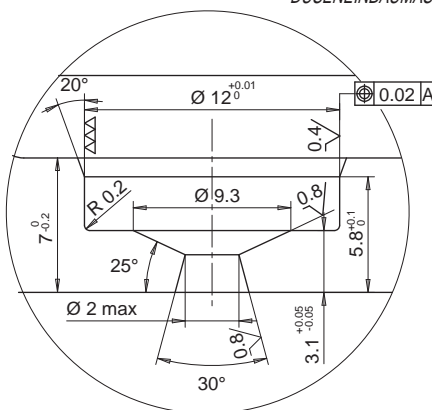
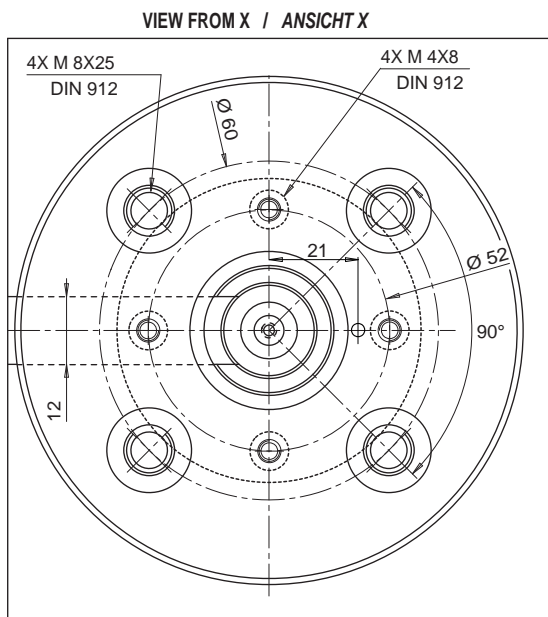

Seal ring is supplied with single nozzles
 Wird mit der Einzeldüse geliefert

Code **E16749**

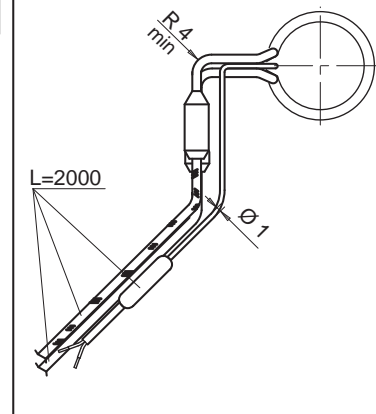

Ø 24^{-0.1}

Ø 17

45°

R 1.5

Ø 23

7

Recommended machining for moulding difficult materials.
 Unverbindlicher Vorschlag zur Verarbeitung kritischer Materialien.

MOULD SEAT - EINBAUMASSE IM WERKZEUG

