

• MONOUGELLO / MONOBUSE

Codice ugello Code buse	L	Codice resistenza Code résistance	Watt	Termocoppia / Thermocouple	
				a massa à la masse	isolata isolé
FLH632056-1DW-ØY/S0..	56	E16674	530	E05302-F32	E16027-F32
FLH632066-1DW-ØY/S0..	66	E16675	545		
FLH632076-1DW-ØY/S0..	76	E16676	545		
FLH632086-1DW-ØY/S0..	86	E16677	580		
FLH632096-1DW-ØY/S0..	96	E16678	580		
FLH632106-1DW-ØY/S0..	106	E16679	615		
FLH632116-1DW-ØY/S0..	116	E16680	615	E05917-F32	E16030-F32
FLH632126-1DW-ØY/S0..	126	E16681	655		
FLH632136-1DW-ØY/S0..	136	E16682	655		
FLH632146-1DW-ØY/S0..	146	E16683	690		
FLH632156-1DW-ØY/S0..	156	E16684	690		
FLH632166-1DW-ØY/S0..	166	E16685	725		
FLH632176-1DW-ØY/S0..	176	E16686	725	E05913-F32	E16031-F32
FLH632186-1DW-ØY/S0..	186	E16687	760		
FLH632196-1DW-ØY/S0..	196	E16688	760		
FLH632206-1DW-ØY/S0..	206	E16689	800		
FLH632216-1DW-ØY/S0..	216	E16690	800		
FLH632226-1DW-ØY/S0..	226	E16691	835		
FLH632236-1DW-ØY/S0..	236	E16692	835	E05913-F32	E16032-F32
FLH632246-1DW-ØY/S0..	246	E16693	870		
FLH632256-1DW-ØY/S0..	256	E16694	870		

Esempio d'ordine: **FLH 6 32 146-1DW-12/S004-JG**

Exemple de désignation:

Monougello - Monobuse

Diametro - Diamètre

Lunghezza - Longueur

Tipo di puntale - Type de pointe

Iniezione Ø 1,2 mm - Injection Ø 1,2 mm

Boccola d'iniezione raggio sferico 40 mm

Reçu de buse rayon spherique 40 mm

Termocoppia a massa - Thermocouple à la masse

Se non specificato fornito termocoppia a massa

Si pas indiqué nous fournissons thermocouple à la masse

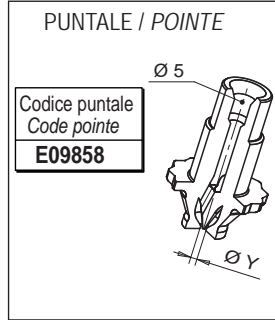

Ø Y foro iniezione Ø Y trou d'injection	
Ø	Suffisso Suffix
0.8	08
0.9	09
1.0	10
1.1	11
1.2	12
1.3	13
1.4	14
1.5	15

Suffisso Suffix	R	Ø u
..S001	0	5.2
..S002	1/2"	8.3
..S003	19.5	7.4
..S004	40	6.3

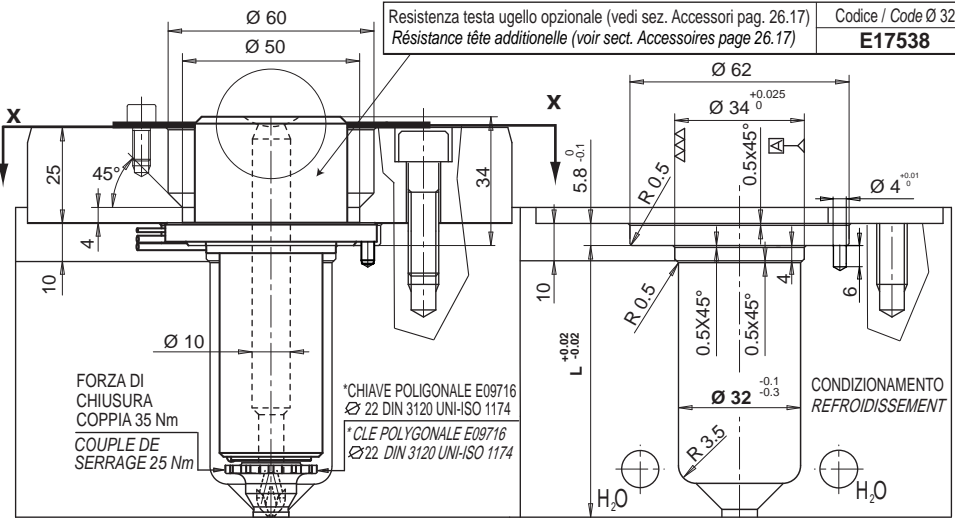
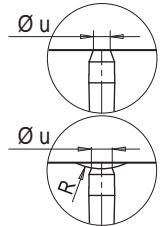

L'ugello in fase di esercizio non deve andare in battuta sull'acciaio della parte mobile dello stampo.
En phase de fonctionnement la buse ne doit pas entrer en contact avec l'acier de la partie mobile du moule.

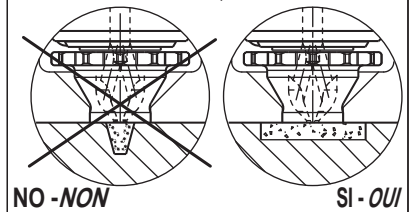

RESISTENZA E TERMOCOPPIA RESISTANCE ET THERMOCOUPLE		
RESISTENZA RESISTANCE	Bianco / Rosso-Bianco Blanc / Rouge-Blanc	230 V
TERMOCOPPIA THERMOCOUPLE	Rosso / Rouge Blu / Bleu	TC+ TC-
Suffisso Suffixe	Descrizione / Description	
.. - JG	Termocoppia a massa con calibratura tipo J Thermocouple à la masse calibré type J	
.. - JU	Termocoppia isolata con calibratura tipo J Thermocouple isolé calibré type J	

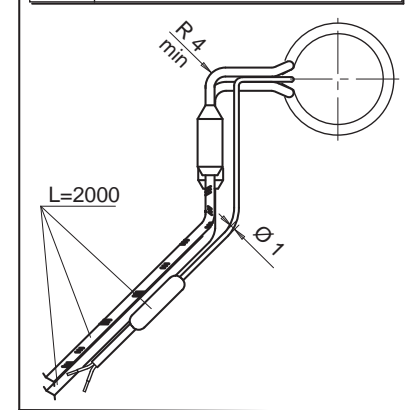
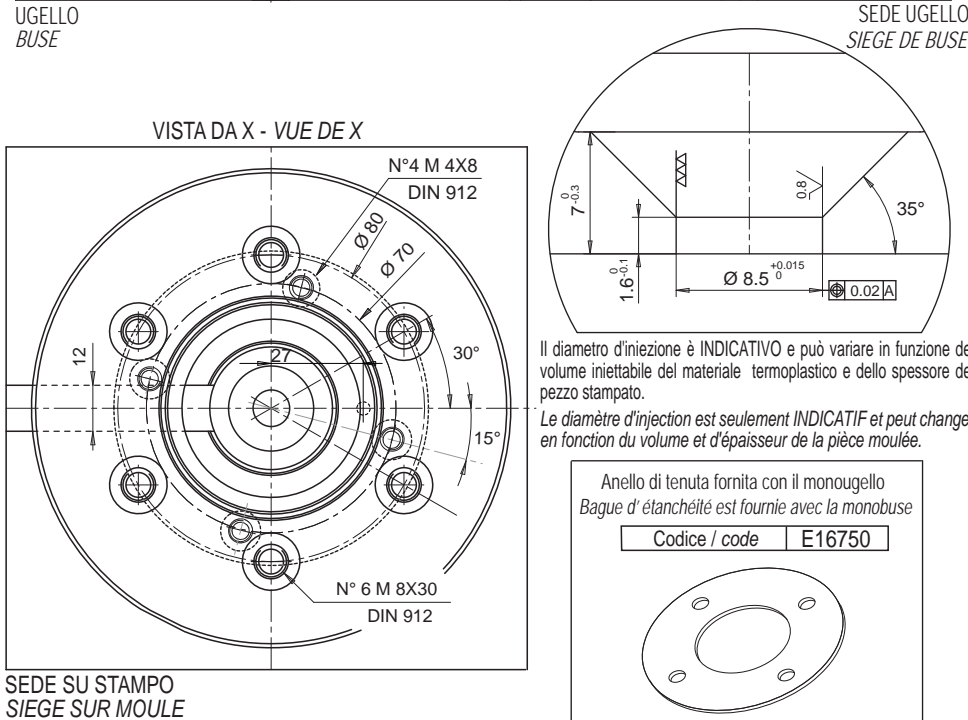

• BOCCOLA CONDIZIONATA / DOUILLE RÉGULÉE

- BOCCOLA CONDIZIONATA
- DOUILLE RÉGULÉE

Codice boccola Code douille	L
E15049	56
E15050	66

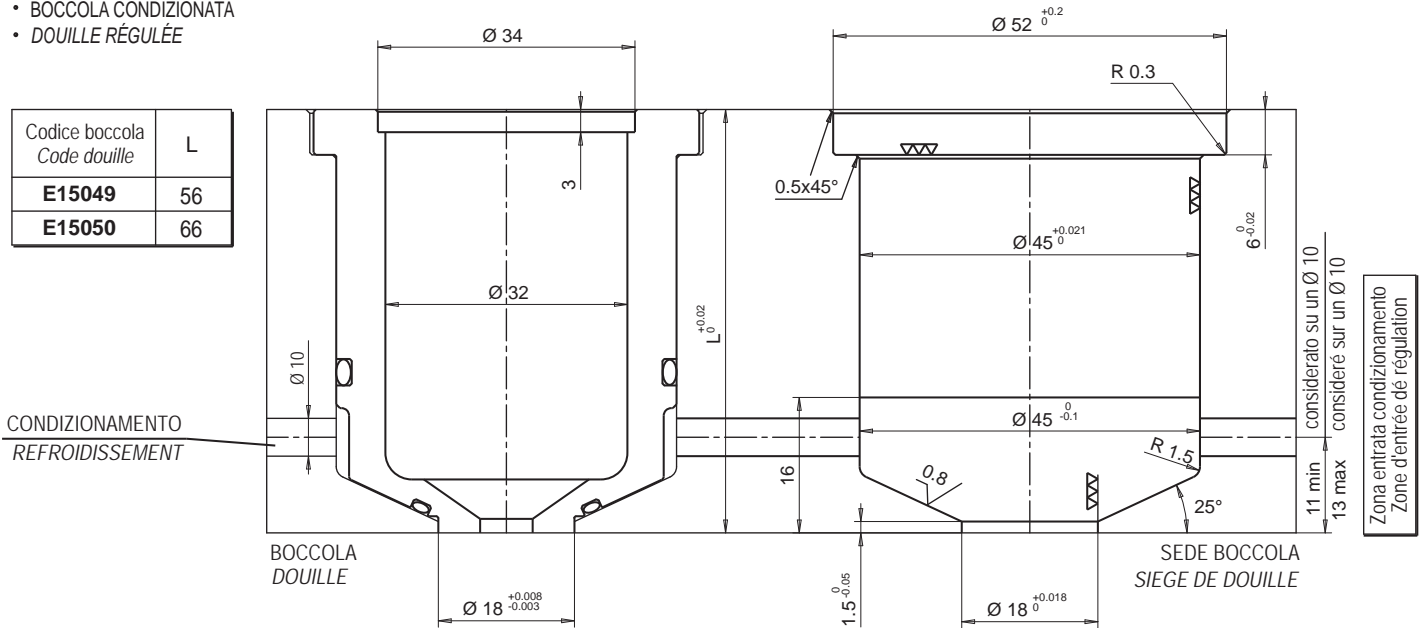

Le boccole portaugello condizionate sono prive di distanziali e vengono fornite alle lunghezze 56 e 66 sopracitate
 Douille porte busette régulée de longueur 56 et 66 livrée sans entretoise.

Le boccole condizionate vengono fornite comprensive di OR Douille régulée livrée avec joint	Parti di ricambio Pieces de rechange	Descrizione Description
	E09900	OR superiore / supérieur
	E09901	OR inferiore / inférieur

