

## MATERIALI PLASTICI / MATIERES PLASTIQUES

amorpho / amorphe cristallino / cristallin	SIGLE MATERIALI SYMBOLE DE LA MATIERE	NOMI COMMERCIALI DESIGNATION COMMERCIALE	
A	ABS	Terluran - Cicolac - Novodur - Lustran - Magnum	
A	ASA	Luran S - Rovel - Gelay - Centrex	
A	CAB	Cellidor B - Tenite	
	C	FEP	Teflon - Fluron - Hostaflo
	C	LCP	Vectra - Xydar
	C	PA 11	Ultramid - Rilsan B
	C	PA 12	Rilsan A
	C	PA 610	Maranil B - Zytel
	C	PA 6	Grilon - Ultramid C - Capron
	C	PA 6.6	Sniamid - Minlon - Ultramid A - Zytel
	C	PBTP	Pocan - Valox - Celanex
A		PC	Macrolon - Lexan - Calibre
	C	PE	Moplen - Lupolen - Dowlex - Tenite
	C	PEEK	Victrex
A		PEI	Ultem
A		PES	Ultrason
	C	PETP	Arnite - Rynite - Crastin - Petra
A		PMMA	Acrylgas - Vedril - Orogas - Plexiglas
	C	POM	Delrin - Ultraform - Hostaform - Celcon
	C	PP	Hostalen - Novolen - Moplen - Fortilene - Pro-Fax - Tenite
A		PPO	Noryl
	C	PPS	Ryton - Fortron
A		PS	Polystyron - Edistir - Styron
A		PSU	Polysulfon - Mindel - Radel
A		PVC	Hostalit - Colorite
A		SAN	Luran - Kostil - Tyril
A		SB	Styrolux - "K" Resin
A		TPU	Desmopan - Texin - Santoprene

MATERIALI PLASTICI / MATIERES PLASTIQUES

sigla <i>symbole de la matière</i>	Nome <i>Material-Name</i>	Temperatura di essiccazione <i>Température d'étuvage</i> C	Tempo di essiccazione <i>Temps d'étuvage</i> (h)	Temp. cilindro d'iniezione <i>Temp. du cylindre d'injection</i> C	Temperatura stampo <i>Température du moule</i> C	Pressione d'iniezione <i>Pression d'injection</i> Kg/cm <sup>2</sup>	Ritiri <i>Retrait</i>	Peso specifico (densità) <i>Poids spécifique (densité)</i>	Resistenza alla temperatura (in continuo) <i>Résistance à la température (en continu)</i>
PA 11	POLIAMMIDE <i>POLYAMIDE</i>	70/80	8/15	190/270	20/100	700 1200	0.3/1.5	1.03 1.08	80/150
PA 12		70/80	8/15	190/270	20/100	700 1200	0.3/1.5	1.03 1.08	80/150
PA 6		80	8/15	240/290	40/120	700 1200	0.5/1.5	1.12 1.14	80/120
PA 66		80	8/15	260/300	40/120	700 1200	0.8/1.5	1.38	80/120
PBTP	POLIBUTILENTEREFTALATO <i>POLYBUTYLENE TEREPHTALATE</i>	120	4	230/280	40/80	560 1800	1.5/2.0	1.31 1.38	49/120
PC	POLICARBONATO <i>POLYCARBONATE</i>	120	4/6	270/380	80/120	800 1400	0.5/0.7	1.19 1.20	120
PMMA	POLIMETILMETACRILATO <i>POLYMETHACRYLATE DE METHYLE</i>	70/100	2/6	190/290	40/90	400 1400	0.1/0.4	1.17 1.20	59/93
POM	POLIACETALICHE <i>POLYACETAL</i>	10	2	180/230	50/120	800 1700	1/3.5	1.41 1.42	90
POM+25FV		110	2	180/230	50/120	800 1700	0.4	1.61	104
PP	POLIPROPILENE <i>POLYPROPYLENE</i>	-	-	200/300	20/90	700 1400	1/2.5	0.9 0.91	46/60
PP+40FV		-	-	200/300	20/90	700 1400	0.2/0.8	1.22 1.23	60/90
PPO	POLIFENILEOSSIDO <i>POLYPHENYLENE OXIDE</i>	80/120	2	260/300	80/110	1000 1400	0.5/0.7	1.06 1.10	-40/+120
PPS	POLIFENILENSOLFURO <i>POLYSULFURE DE PHENYLENE</i>	150/170	4	300/360	40/200	750 1500	0.7	1.34	230
PS	POLISTIRENE <i>POLYSTYRENE</i>	-	-	170/280	20/60	700 2100	0.4/0.7	1.05	65/76
SB		-	-	190/280	10/80	700 2100	0.4/0.7	1.03 1.06	60/79
PS		-	-	190/280	220/80	700 2100	0.2/0.6	1.05 1.09	60/80
PSU	POLISOLFONE <i>POLYSULFONE</i>	135/150	3/4	310/390	95/115	1000 1500	0.7/0.8	1.24	-100/+180

sigla symbole de la matière	Nome Material-Name	Temperatura di essiccazione Température d'étuvage C	Tempo di essiccazione Temps d'étuvage (h)	Temp. cilindro d'iniezione Temp. du cylindre d'injection C	Temperatura stampo Température du moule C	Pressione d'iniezione Pression d'injection Kg/cm <sup>2</sup>	Ritiri Retrait	Peso specifico (densità) Poids spécifique (densité)	Resistenza alla temperatura (in continuo) Résistance à la température (en continu)
SVP	CLORURO DI POLIVINILE POLYCLORURE DE VINYLE	-	-	160/190	10/20	560 / 1750	1/5	1.16 / 1.35	-
HPVC		-	-	170/210	10/60	700 / 2800	0.1/0.5	1.30 / 1.58	50/80
SAN	STIRENE ACRILONITRILE STYRENE ACRYLO NITRILE	85	2/4	200/260	50/80	700 / 2300	0.2/0.7	1.07 / 1.10	60/95
SAN <sup>+20 FV</sup> +30 FV		85	2/4	200/260	50/80	1050 / 2800	0.1/0.2	1.20 / 1.46	90/103
ABS	ACRIL BUTADIENE STIRENE ACRYLO NITRILE BUTADIENE STYRENE	70/80	2	200/250	50/80	550 / 1750	0.4/0.9	1.03 / 1.06	71/93
ABS		70/80	2	250/300	50/80	550 / 1750	0.4/0.9	1.05 / 1.08	85/165
ABS <sup>+20 FV</sup> +40 FV		70/80	2	200/250	50/80	1000 / 2800	0.1/0.2	1.22 / 1.36	90/110
ASA	STIRENE ACRILONITRILE + ESTERE ACRILICO ACRYLATE STYRENE ACRYLONITRILE	80/90	2	200/250	40/85	800 / 1800	0.4/0.7	1.07	80/90
CAB	ACETO BUTIRRATO DI CELLULOSA ACETO BUTYRATE DE CELLULOSE	80	3	180/230	40/70	800 / 1200	0.4/0.7	1.16 / 1.22	60/110
FEP	TETRAFLUOROETILENE ESAFLUOROPROPILENE TETRAFLUOROETHYLENE HESAFLUOROPROPYLENE	-	-	330/420	-	- / -	3/6	2.10 / 2.20	260/280
LCP	LIQUIDO CRISTAL POLIMERO LIQUID CRISTAL POLYMERE	150/160	4	285/330	100/150	140 / 400	0.1/1	1.4 / 1.9	220/240
LDPE	POLIETILENE POLYETHYLENE	-	-	160/240	20/70	500	1.5/3.5	0.92 / 0.94	80/95
HDPE	POLIETILENE POLYETHYLENE	-	-	180/300	10/90	1200	2/4	0.94 / 0.96	80/105
PEEK	POLIETEREETERECHETONE POLYETHER ETHERCETONE	150	3	370/390	160/170	700 / 1400	0.7/1.2	1.30	250
PEI	POLIETEREIMMIDI POLYETHER IMIDE	150	4	340/425	100/150	800 / 2000	0.5/0.7	1.27 / 1.42	-200/+260
PES	POLIETERESULFONE POLYETHER SULFONE	135/150	3/4	340/390	120/160	1000 / 1500	0.6	1.37	200
PETP	POLIETILENTEREFTALATO POLYETHYLENE THEREPHTALATE	75/90	3/4	260/290	30/140	1000 / 1700	1/2	1.37	-40/+110
TPU	URETANI TERMOPLASTICI POLYURETHANE THERMOPLASTIQUE	100/110	2	190/230	20/30	400 / 1000	0.2/2	1.14 / 1.26	-40/+80

MATERIALI PLASTICI / MATIERES PLASTIQUES

TABELLE DEI MATERIALI / TABLEAUX DES MATIERES

GRAFICO PER IL CALCOLO DEI FORI DI INIEZIONE  
 TABLEAU POUR LE CALCUL DES SEUILS D'INJECTION

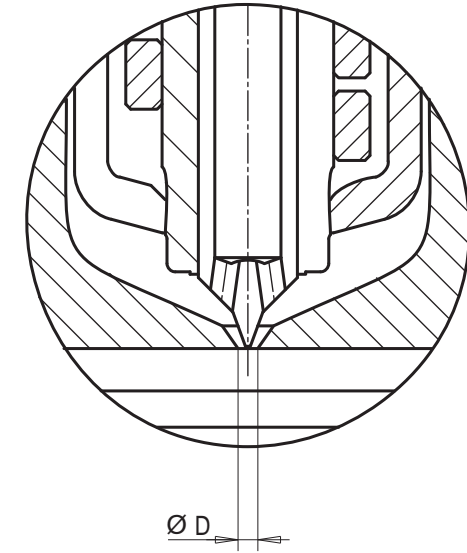
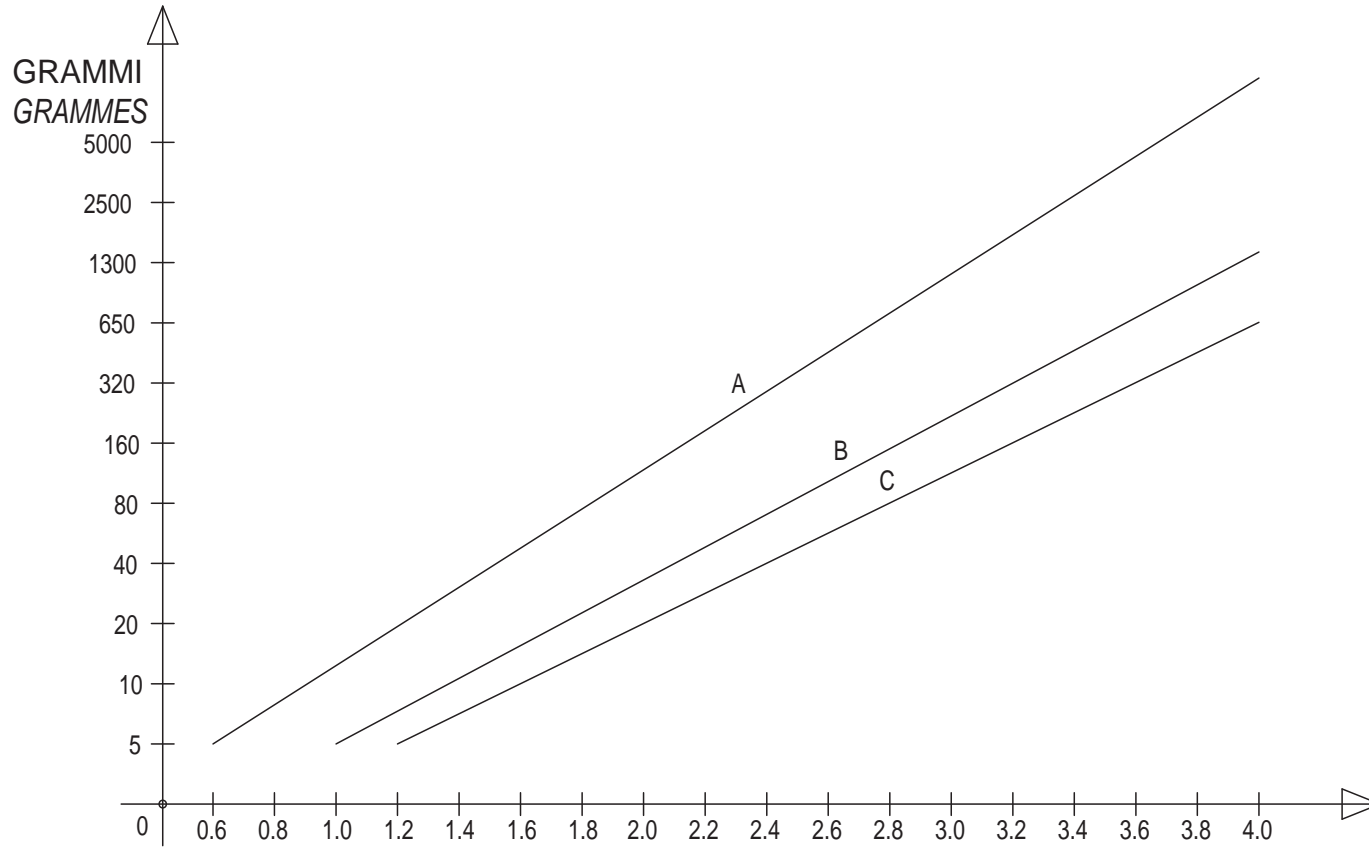

- |   |                                     |                         |
|---|-------------------------------------|-------------------------|
| A | Materiali a bassa viscosità         | : PE - PP               |
| B | Materiali a media viscosità         | : ABS - POM - PA        |
| C | Materiali ad alta viscosità         | : PC - PMMA             |
|   |                                     |                         |
| A | <i>Matières à faible viscosité</i>  | <i>: PE - PP</i>        |
| B | <i>Matières à viscosité moyenne</i> | <i>: ABS - POM - PA</i> |
| C | <i>Matières à haute viscosité</i>   | <i>: PC - PMMA</i>      |

DIAMETRO FORO DI INIEZIONE D  
 DIAMETRE DU SEUIL D'INJECTION D