

Manifold / Verteilerblock		
CODE	NOZZLE TYPE / DÜSENTYP	d
E90285-40	DN18 - F11	Ø 4
E90285-60	KS5/8 Ø22-F16-F24-DN22	Ø 6
E90285-80	KS5/8 Ø30 - DN30	Ø 8

SPARE PARTS / ERSATZTEILE					
CODE	DESCRIPTION BESCHREIBUNG	Q.TY MENGE	CODE	DESCRIPTION BESCHREIBUNG	Q.TY MENGE
E92046	Heater 240 VOLT Power 2000 WATT each Heizung 240 VOLT 2000 WATT pro Stück	2	E08562	Thermocouple Fe-CuNi J type calibration Thermofühler Fe-CuNi Type J.	2

— See page 26.02 for the information related to the ACCESSORIES / Zubehör s. Seite 26.02 —

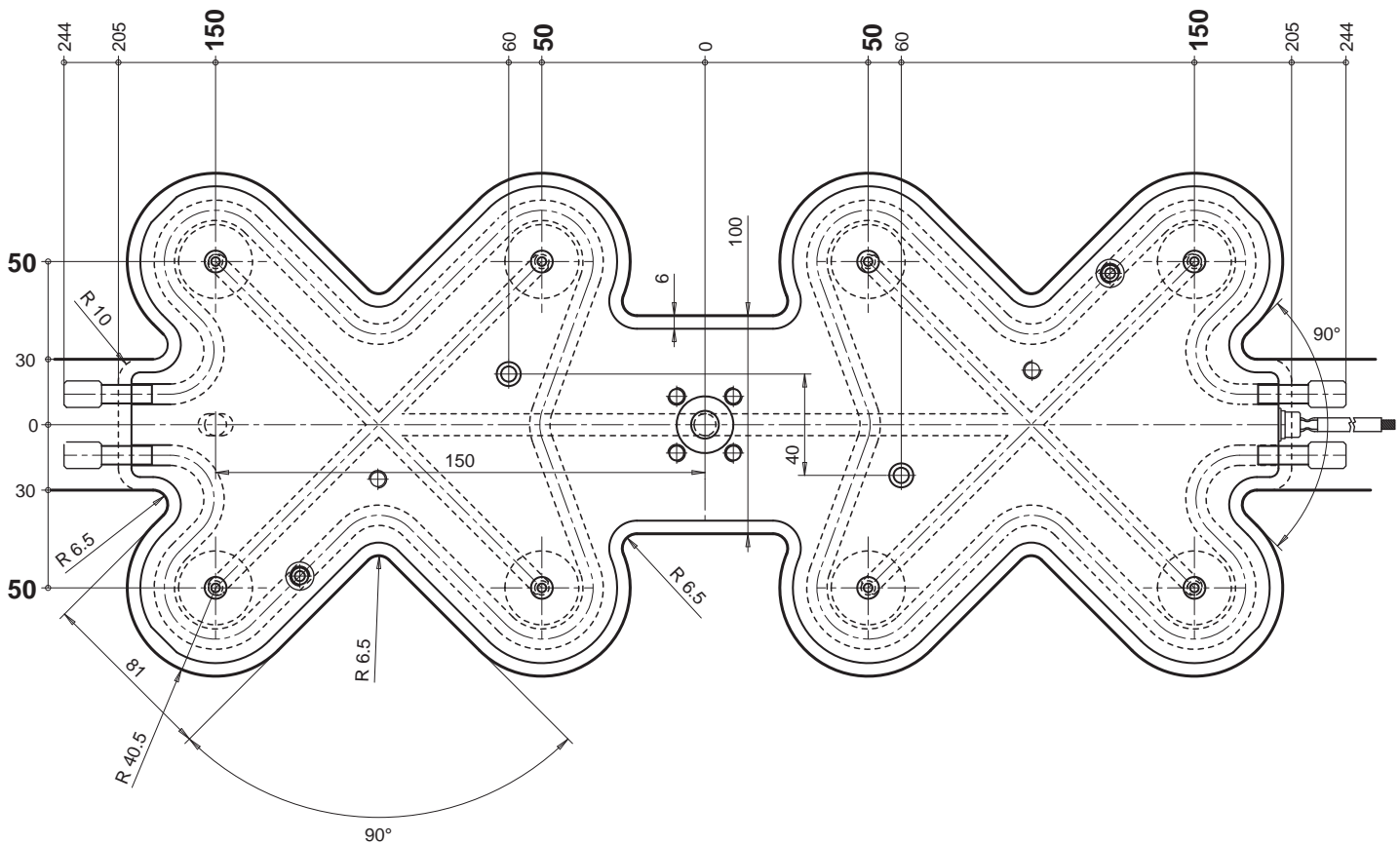
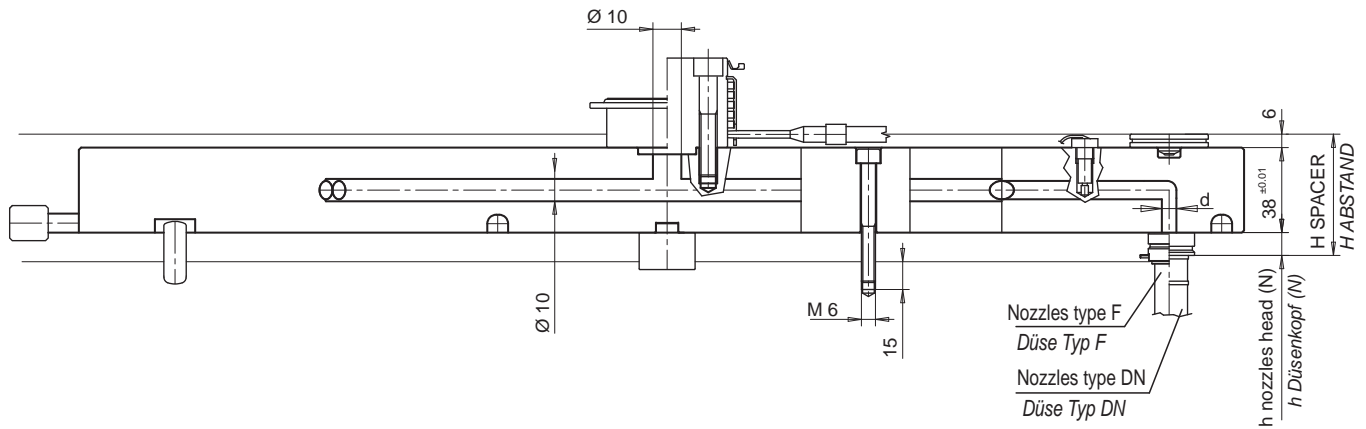

$$H \text{ Spacer / Abstand} = (N + 38 + 6) + [(N + 38 + 6) \cdot \Delta t \cdot K] - 0.05 = \text{mm}$$

N = nozzle head / Abstand

Δt = Temperature difference between the hot runner and the mould / Temperaturunterschied zwischen dem Heisskanal und dem Werhreg.

K = Steel thermal expansion coefficient / Wärmeausdehnungs Koeffizient für Stahles (= 0.0000125)