

# Live demo at Hall 15 - Booth A23

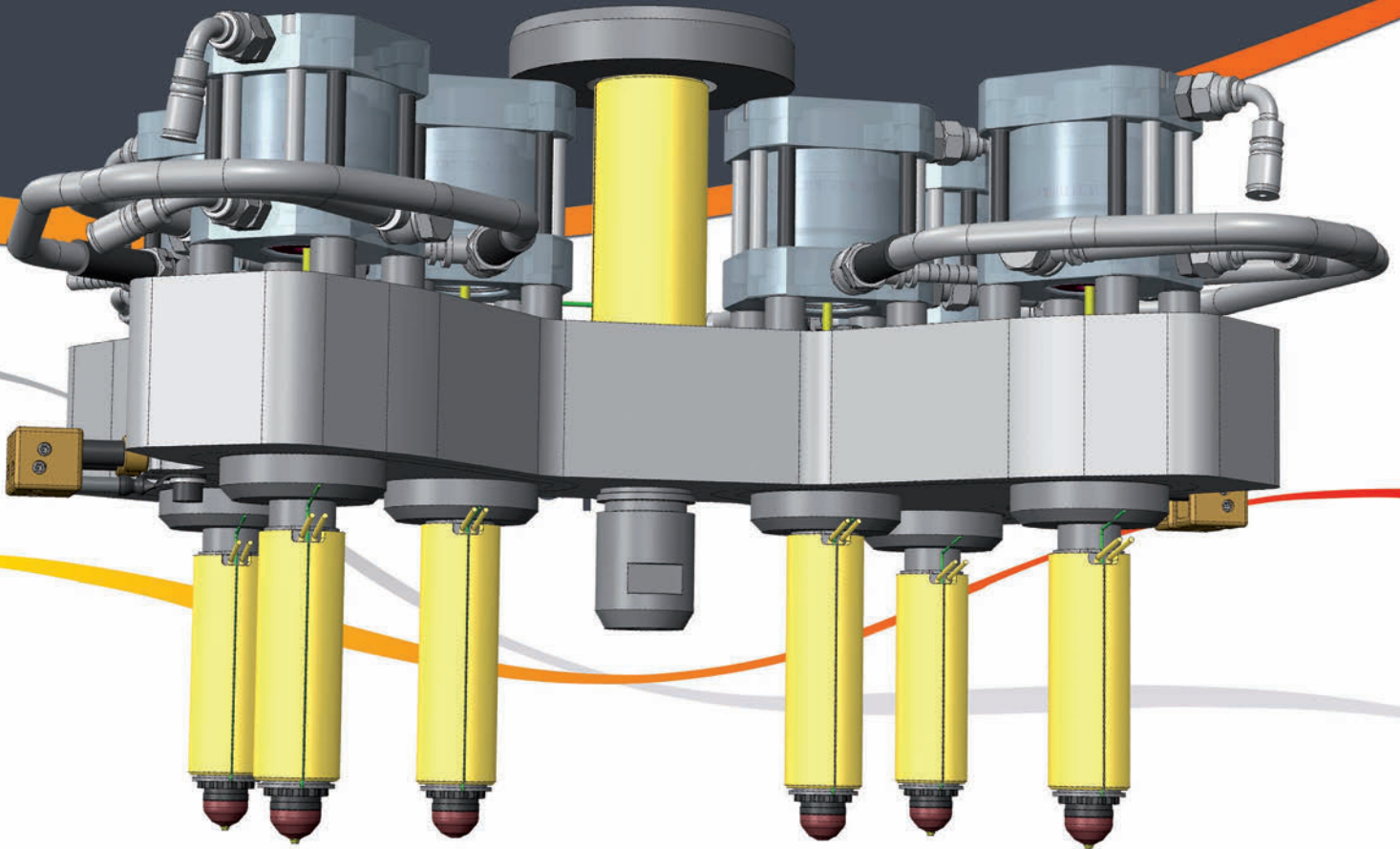

- **Injection system:** Thermoplay SS161246
- **Nozzles:** N.4 FN-AV 3BT screw-in nozzles diam.32 , L=104,58 mm  
N.2 FN-AV 3BT screw-in nozzles diam.32 , L=106 mm
- **Valve gate actuation:** pneumatic
- **Moulded part:** Box with IML
- **Dimensions:** 380x280x236 mm
- **Weight:** 415 g
- **Avg thickness:** 1,25 mm
- **Material:** Polypropylen
- **Injection moulding cycle:** 2,24 sec
- **Total cycle time:** 23 sec
- **Hot runner temperature:** 240° C
- **Mold temperature:** 40° C
- **Mold maker:** Mondial Stampi, Hall 1 Booth D11
- **Injection machine:** Multipower HE 500
- **Temperature controller:** Internal on the press machine

Fill time = 1.401[s]

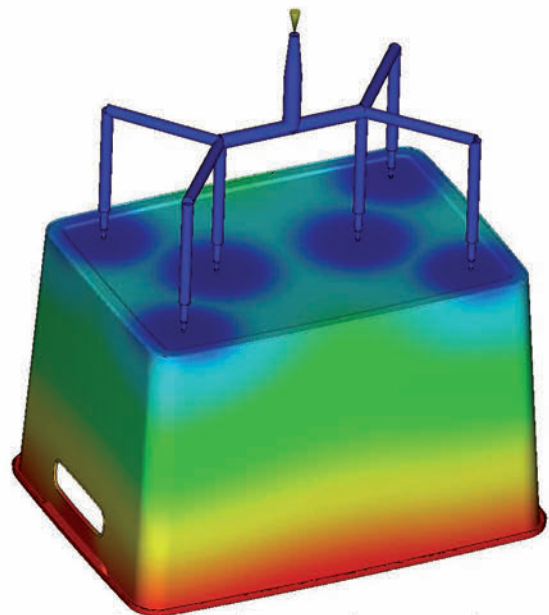

AUTODESK  
MOLDFLOW INSIGHT

Scale (300 mm)



-56  
22  
12

**THERMOPLAY**  
HotRunnerSystems

A business of BARNES GROUP INC