

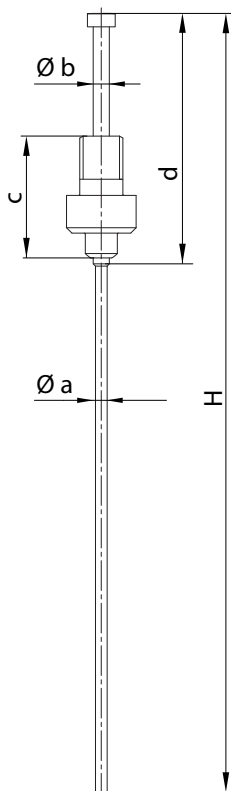

Gruppo spillo - Valve gate pin group



Valve Gate type / Tipo gr.ott.	S20 - S28 - S32				K32	
Nozzle type / Tipo ugello	TF12 - TF17 - TF23 - TD18 - TD22					
Pin group code / Codice gr.spillo	<b>E18330</b>	<b>E20309</b>	<b>E18331</b>	<b>E20310</b>	<b>E18332</b>	<b>E18333</b>
Ø a					Ø 2.5	
Ø b					Ø 3.5	
d	82				57	
c	22.5	37	22.5	37	22.5	
H	280		500		280	500

Valve Gate type / Tipo gr.ott.	S28 - S32				K32	
Nozzle type / Tipo ugello	FN32 - TD30					
Pin group code / Codice gr.spillo	<b>E18334</b>	<b>E20313</b>	<b>E18335</b>	<b>E20314</b>	<b>E18334</b>	<b>E20313</b>
Ø a					Ø 3.3	
Ø b					Ø 3.5	
d					98	
c	22.5	37			22.5	
H	280	500	280	500		

Valve Gate type / Tipo gr.ott.	S60 - K40					
Nozzle type / Tipo ugello	FN46 - DN44					
Pin group code / Codice gr.spillo	<b>E18336</b>			<b>E18337</b>		
Ø a					Ø 5.8	
Ø b					Ø 6	
d					120	
c					30.5	
H	400			600		

Gruppo contrasto - Pressure group

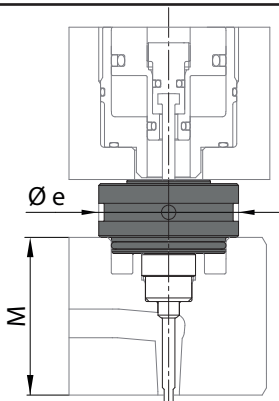

Manifold type / Tipo piastra	C - Conventional / Tradizionale					
Valve gate type / Tipo gr.otturatore	S20		S28 - S32		S60	
Pressure gr. code / Codice gr.contrasto	<b>E20327 - *</b>		<b>E20328 - *</b>		<b>E21474</b>	
Nozzle type / Tipo ugello	TFØ12/17/23 - TDØ18/22		TFØ12/17/23/32 TDØ18/22/30		FNØ46- DN44	
Ø e	Ø 31		Ø 39		Ø 54	
*M	44 - 52 - 62 - TT					

Manifold type / Tipo piastra	B - bolted down					
M	44		52		62	
Ø e	Ø 28	Ø 36	Ø 28	Ø 36	Ø 28	Ø 36
Pressure gr. code / Codice gr.contrasto	<b>E21375</b>	<b>E21466</b>	<b>E21383</b>	<b>E21467</b>	<b>E21384</b>	<b>E21468</b>
Valve gate type / Tipo gr.otturatore	S20 - S28 - S32					
Nozzle type / Tipo ugello	TFØ12/17/23/32 - TDØ18/22/30					

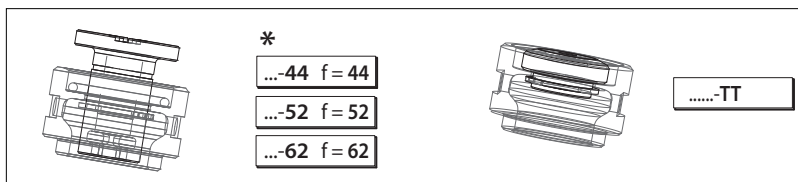

Gruppo otturatore - Valve gate group

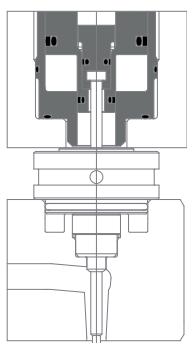

Manifold type / Tipo piastra	C - Conventional / Tradizionale					
Valve gate type / Tipo gr.otturatore	S				K	
Valve gate type / Tipo gr.otturatore	S20 - HY	S28 - PN	S32 - PN	S32 - HY	S60 - PN	K32 - PN K40 - PN
Valve gate gr.code / Codice gr.otturatore	E21105 - *	E21474 - *	E19399 - *	E21487 - *	E18327	E18326 E18329
Nozzle type / Tipo ugello	TFØ12/17/23 TDØ18/22	TFØ12/17/23/32 TDØ18/22/30		FNØ46 DNØ44	TFØ12/17/23/32 TDØ18/22/30	FNØ46 DNØ44
Manifold type / Tipo piastra	B - bolted down					
Valve gate type / Tipo gr.otturatore	S					
Valve gate type / Tipo gr.otturatore	S20 - HY	S28 - PN	S32 - PN	S32 - HY		
Valve gate gr.code / Codice gr.otturatore	E21360	E21492	E21361		E21362	
Nozzle type / Tipo ugello	TFØ12/17/23 TDØ18/22	TFØ12/17/23/32 TDØ18/22/30		TFØ12/17/23/32 TDØ18/22/30		

**K40-PN**

"K" TYPE VALVE GATE GROUP - BORE PISTON 40 - PNEUMATIC  
GRUPPO OTTURATORE TIPO "K" - ALESAGGIO PISTONE 40 - PNEUMATICO

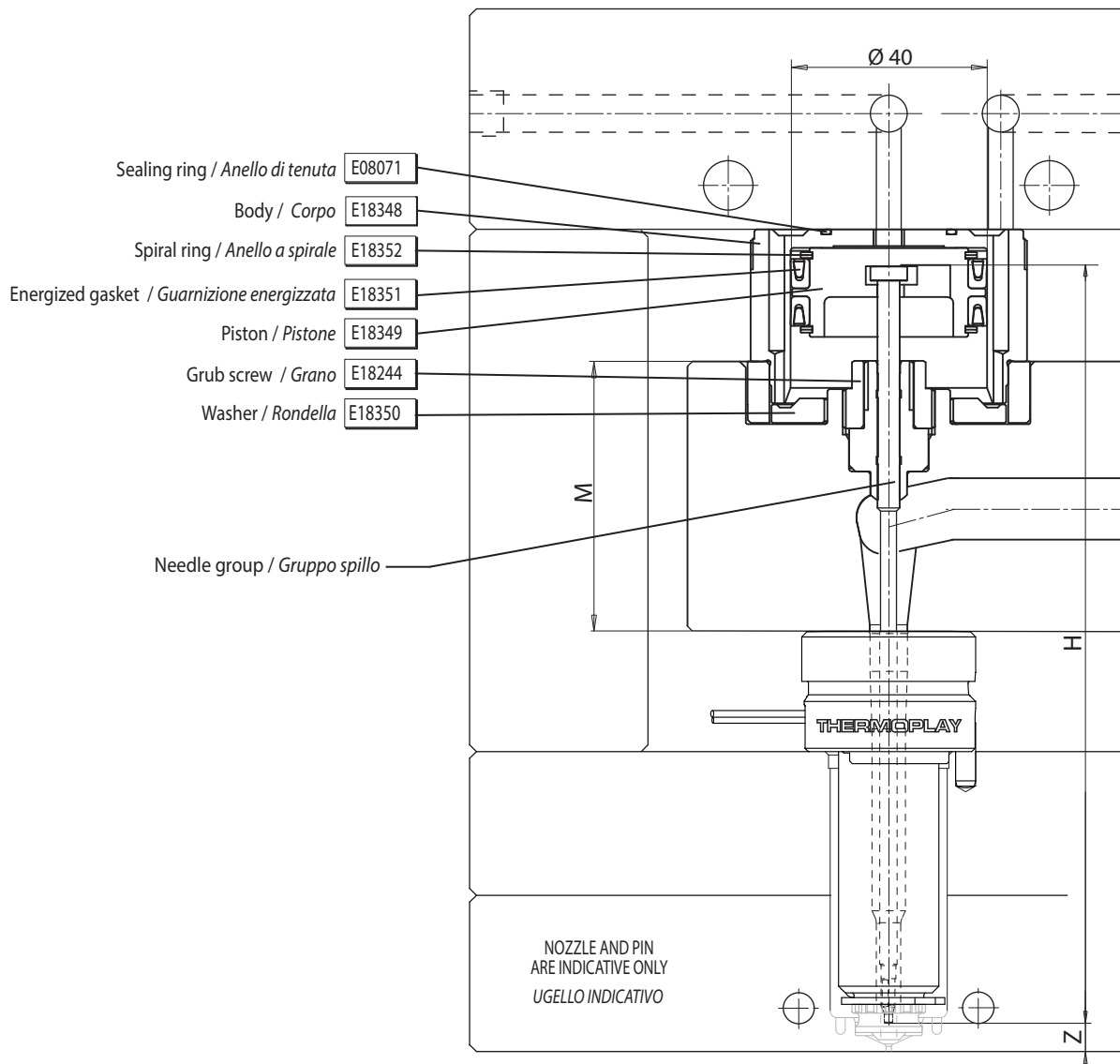

Z = Pin stroke 16 mm / Corsa spillo 16 mm

M = Manifold height / Altezza distributore

H = Pin length / Lunghezza spillo

**ATTENZIONE!**

Si consiglia di non azionare il gruppo otturazione a sistema d'iniezione freddo.

**FUNZIONAMENTO PNEUMATICO consigliati 10 bar.**

Nelle prove eseguite con stampo non fissato sulla pressa **NON** utilizzare pressioni oltre i 5 bar.

**ATTENTION!**

Do not activate the shut off group when the injection system is cold

**PNEUMATIC OPERATION: 10 bar ADVISED**

When testing the injection system on the bench, use 5 bar maximum pressure.

FOR NOZZLES / PER UGELLI

**TF3-TF3B-TF3DSL A-TF3DSL U Ø46 - TD3 Ø44**



"K" TYPE VALVE GATE GROUP - BORE PISTON 40 - PNEUMATIC  
GRUPPO OTTURATORE TIPO "K" - ALESAGGIO PISTONE 40 - PNEUMATICO

**K40-PN**

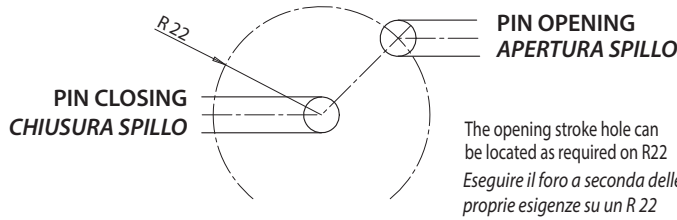

VIEW FROM A-A / VISTA DA A-A

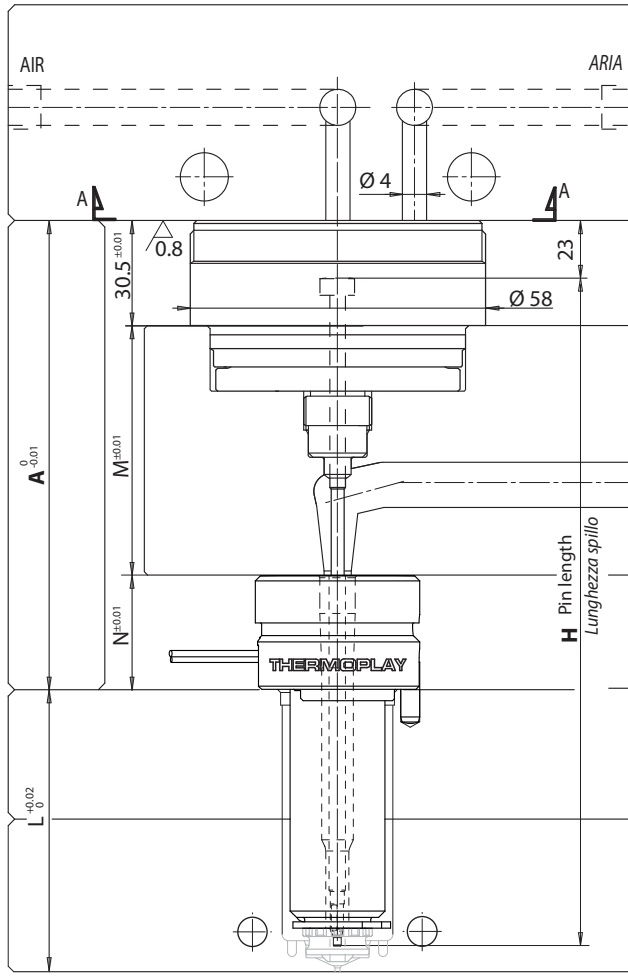

**ATTENTION!**  
Do not activate the shut off group when the injection system is cold  
**PNEUMATIC OPERATION: 10 bar ADVISED**  
When testing the injection system on the bench, use 5 bar maximum pressure.

**ATTENZIONE!**  
Si consiglia di non azionare il gruppo otturazione a sistema d'iniezione freddo.  
**PRESSIONE CONSIGLIATA 10 bar.**  
Nelle prove eseguite con stampo non fissato sulla pressa **NON** utilizzare pressioni oltre i 5 bar.

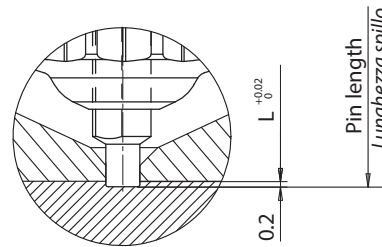

Fastening grub screw with hexagon key (Ø12 DIN 3120 UNI ISO 1174)  
Tightening torque 50 Nm  
Chiusura grano chiave esagonale (Ø12 DIN 3120 UNI ISO 1174)  
Coppia di serraggio 50 Nm

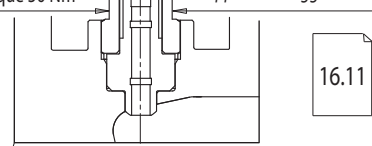

- L** = Nozzle length / Lunghezza ugello
- A** = Spacers thickness / Altezza distanziali
- N** = Nozzle head thickness / Altezza testa ugello
- M** = Manifold height / Altezza distributore

PIN LENGTH ADJUSTMENT WASHER  
RONDELLA DI REGOLAZIONE CORSA

Code / Codice	<b>E18350</b>
---------------	---------------

\* 1 = maximum machining to adjust pin length.  
\* 1 = spessore massimo da asportare per regolare la corsa a seconda delle proprie esigenze.

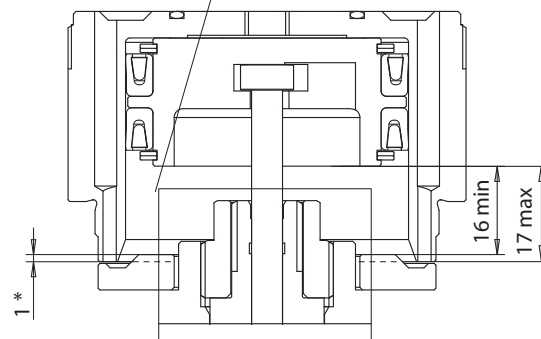

FOR NOZZLES / PER UGELLI

**TF3-TF3B-TF3DSLA-TF3DSL** Ø46 - TD3 Ø44



S20-HY

S28-PN

S32-PN

S32-HY

S60-PN

K32-PN

K40-PN

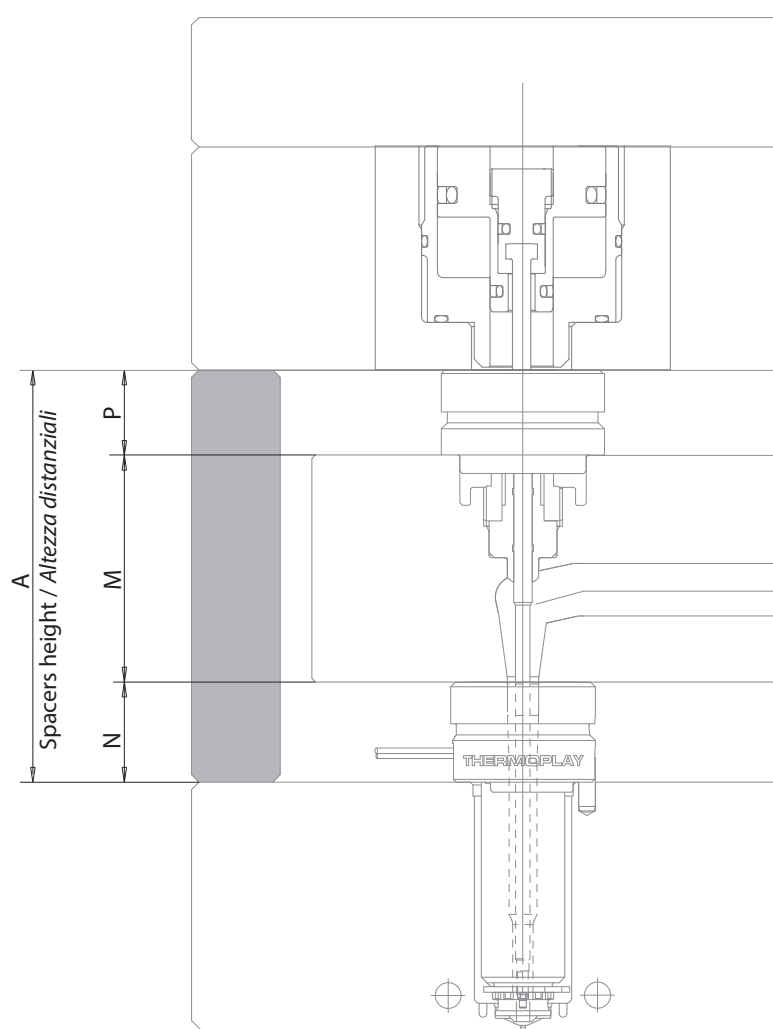

$$A = (N+M+P)+[(N+M+6) \times \Delta t \times K]-0.05 = \text{mm}$$

<b>A</b>	Spacer height / Altezza distanziali								
	<b>Nozzle type / Tipo ugelli</b>								
	TF12	TF17	TF23	TF32	TF46	TD18	TD22	TD30	TD44
<b>N</b>	13	18	20	20	25	18	20	20	25
<b>M</b>	Manifold height / Altezza distributore								
	<b>Actuator group / Gruppo otturatore</b>								
	S20HY	S28PN	S32HY	S32PN	S60PN	K32PN	K40PN		
<b>P</b>	16				20		21.5	30.5	
<b>ΔT</b>	Temperature difference between manifold and mold / Differenza di temperatura tra canale caldo e stampo								
<b>k</b>	Coefficient of thermal expansion for steel / Coeficente di dilatazione termica dell'acciaio 0.0000125								
<b>0.05</b>	Theoretical compression value / Valore teorico di chiusura								



K32-PN

K40-PN

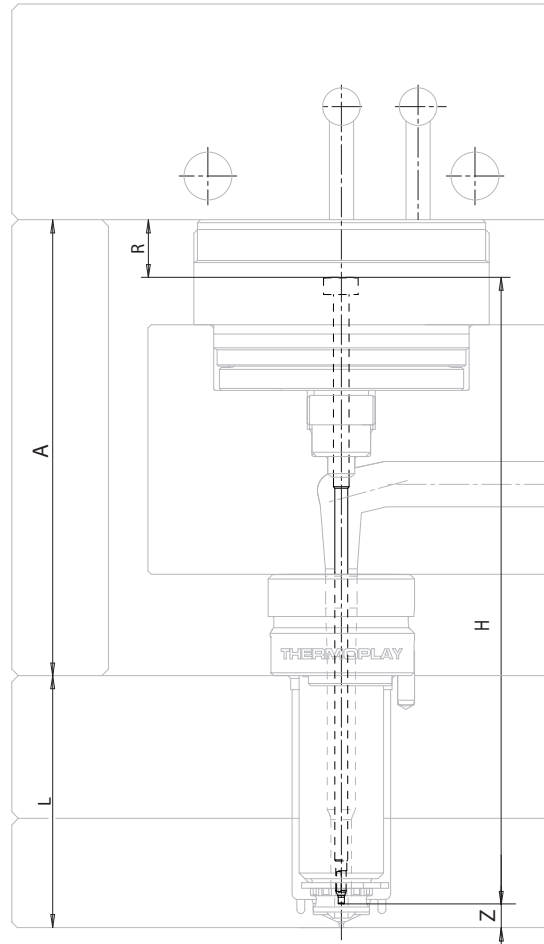

$$H = (L+A-R) - [(L+A-R) \times \Delta t \times k] + N = \text{mm}$$

H	Pin length (cold) / Lunghezza spillo a freddo				
L	Nozzle length / Lunghezza ugello				
A	Spacer height (including expansion) / Misura dei distanziali comprensiva della dilatazione per il serraggio				
	<b>Valve gate group type / Tipo gruppo otturatore</b>				
	K32PN	K40PN			
R	16	23			
Z	10		16		
	<b>Nozzle TIP type / Tipo puntale ugello</b>				
	TF3/3B-TF3D/3DSL A Ø12-17-23-32-46	TD18/22/30/44-3	TF17/23-3DSL U	TF32-3DSL U	TF44-3DSL U
N	0.2		0.63	1.02	1.76
k	Coefficient of thermal expansion for steel / Coeficente di dilatazione termica dell'acciaio 0.0000125				
ΔT	Temperature difference between manifold and mold / Differenza di temperatura tra canale caldo e stampo				



NOZZLE / UGELLO  
**TF3 Ø12**

INDICATIONS FOR EXECUTION OF PIN PROFILE / INDICAZIONI PER L'ESECUZIONE DEL PROFILO PUNTA SPILLO  
(execution customer care - a cura cliente)

## CILINDRIC / CILINDRICO

## CONICAL / CONICO

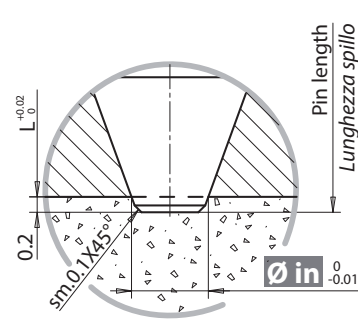
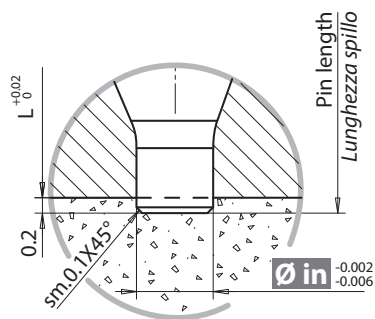
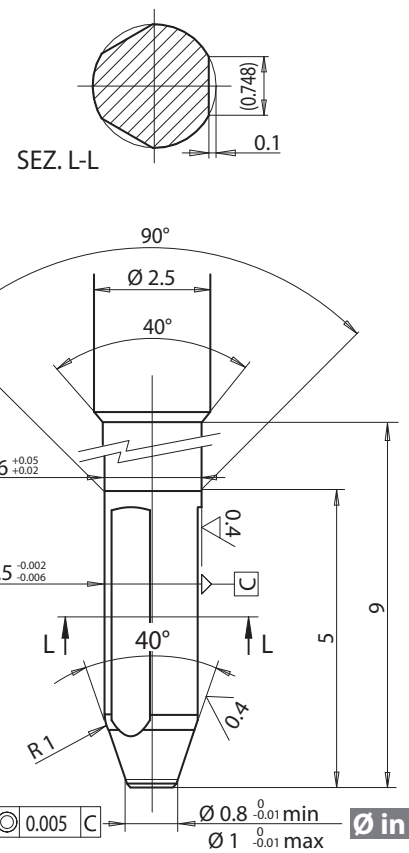
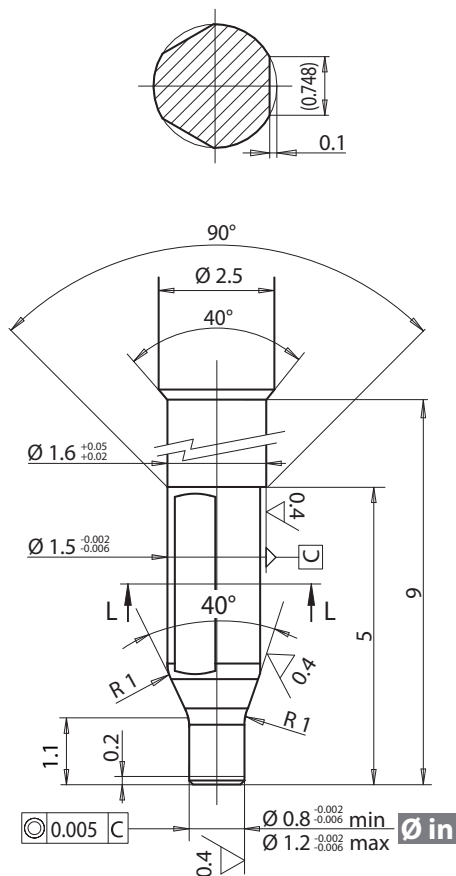

### ATTENTION - ATTENZIONE!

With conical shut off, if pin stroke adjustment or length are not correct, damage can occur to steel in the gate area.  
Nella chiusura **conica** l'errata regolazione della corsa dello spillo o della sua lunghezza potrebbero causare danni alla matrice



NOZZLE / UGELLO  
**TD3 Ø18**

INDICATIONS FOR EXECUTION OF PIN PROFILE / INDICAZIONI PER L'ESECUZIONE DEL PROFILO PUNTA SPILLO  
(execution customer care - a cura cliente)

### CILINDRIC / CILINDRICO

### CONICAL / CONICO

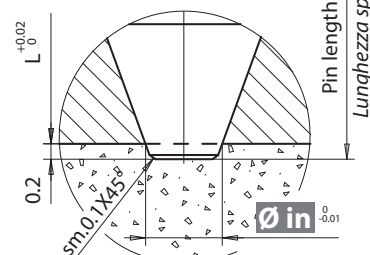
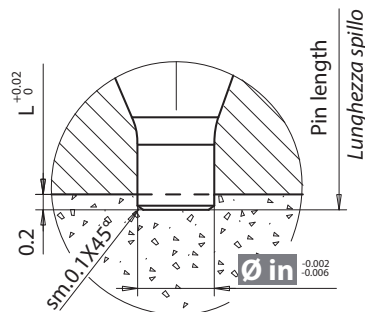
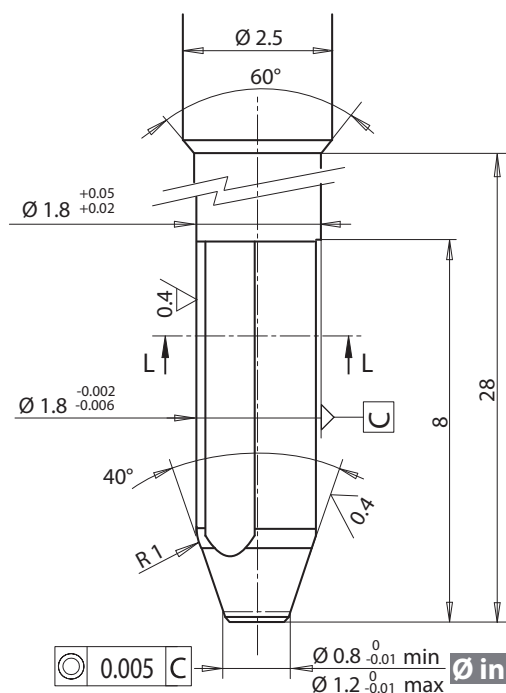
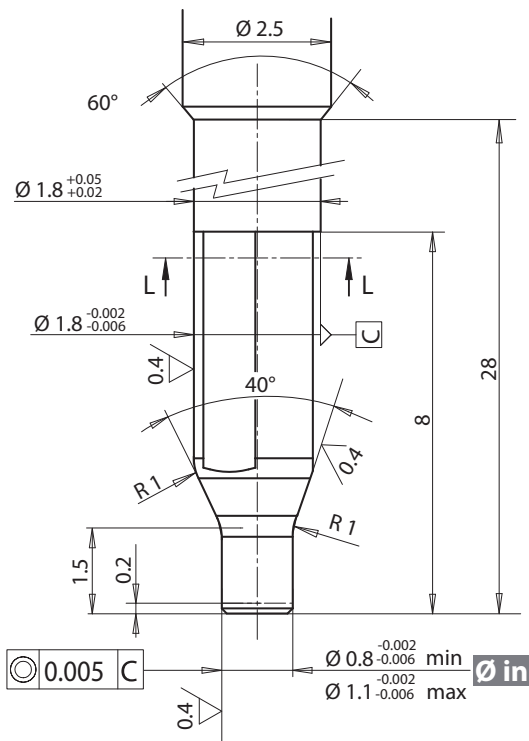
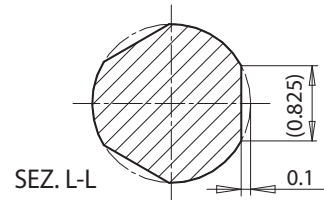
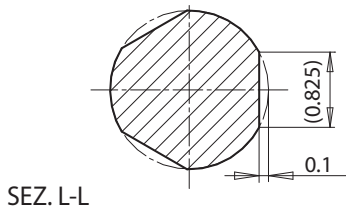

#### ATTENTION - ATTENZIONE!

With conical shut off, if pin stroke adjustment or length are not correct, damage can occur to steel in the gate area.  
*Nella chiusura conica l'errata regolazione della corsa dello spillo o della sua lunghezza potrebbero causare danni alla matrice*





NOZZLE / UGELLO  
**TF3-TF3B-TD3**

## CILINDRIC / CILINDRICO

(execution customer care - a cura cliente)

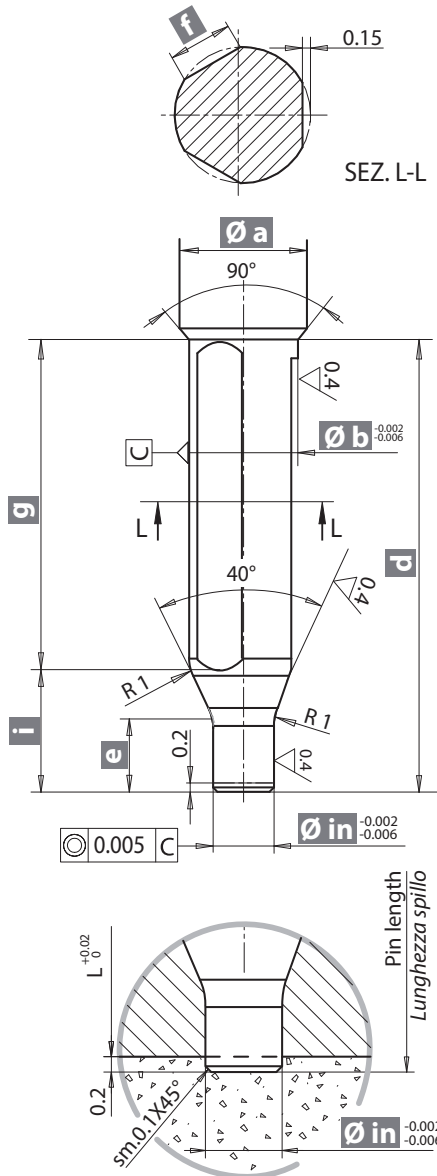

## CONICAL / CONICO

(execution customer care - a cura cliente)

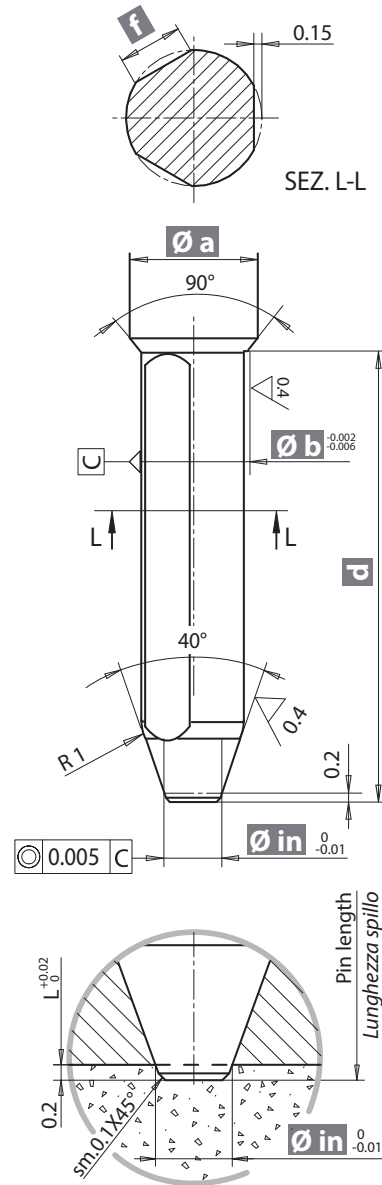

**ATTENTION - ATTENZIONE!**  
With conical shut off, if pin stroke adjustment or length are not correct, damage can occur to the gate area.  
*Nella chiusura conica l'errata regolazione della corsa dello spillo o della sua lunghezza potrebbero causare danni alla matrice*

CILINDRIC / CILINDRICO						
Nozzle type / Tipo ugello						
TF17	TF23	TF32	TF46	TD22	TD30	TD44
0.8	0.8	1.6	3.5	0.8	1.6	3.5
1.8	2	3	5.5	1.3	2	4
2.5	2.5	3.3	5.8	2.5	3.3	5.8
2.4	2.4	3.2	5.7	2.4	3.2	5.7
9	9	9	13	9	9	13
1.5	1.5	1.8	2.2	1.5	1.8	2.2
1.16	1.16	1.35	1.82	1.16	1.35	1.82
-	-	7.7	11.2	-	7.7	11.2
-	-	1.3	1.8	-	1.3	1.8

CONICAL / CONICO						
Nozzle type / Tipo ugello						
TF17	TF23	TF32	TF46	TD22	TD30	TD44
0.8	0.8	1.6	3.5	0.8	1.6	3.5
1.3	1.3	2.5	4.5	1.6	2.5	4.5
2.5	2.5	3.3	5.8	2.5	3.3	5.8
2.4	2.4	3.2	5.7	2.4	3.2	5.7
9	9	9	13	9	9	13
-	-	-	-	-	-	-
1.16	1.16	1.35	1.82	1.16	1.35	1.82
-	-	7.7	11.2	-	7.7	11.2
-	-	1.3	1.8	-	1.3	1.8



NOZZLE / UGELLO  
**TF3D-TF3DSL A**

## CILINDRIC / CILINDRICO

(execution customer care - *a cura cliente*)

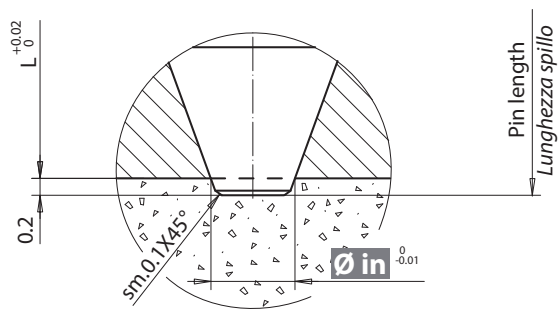
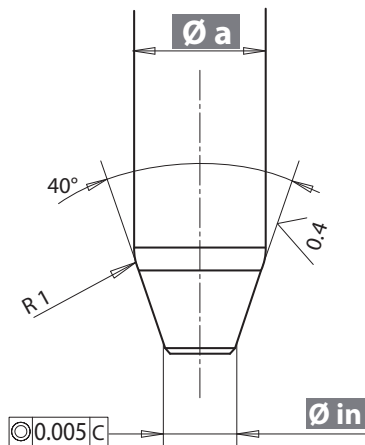

NOZZLE / UGELLO  
**TF3DSL U**

## CONICAL / CONICO

(execution customer care - *a cura cliente*)

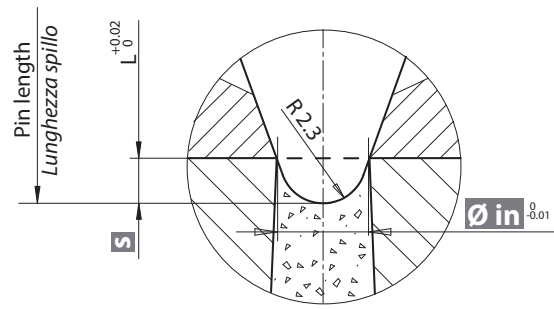
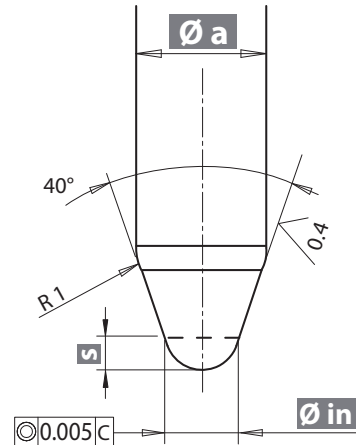

### ATTENTION - ATTENZIONE!

With conical shut off, if pin stroke adjustment or length are not correct, damage can occur to steel in the gate area.  
*Nella chiusura **conica** l'errata regolazione della corsa dello spillo o della sua lunghezza potrebbero causare danni alla matrice*

Nozzle type / Tipo ugello								Nozzle type / Tipo ugello			
3D				3DSL A				3DSL U			
TF17	TF23	TF32	TF46	TF17	TF23	TF32	TF46	TF17	TF23	TF32	TF46
0.8	1.6	3.5		0.9	1.7	3.5		1.3	2.5	3.3	5.8
	1.7	3.6			1.9	3.7					
0.9	1.8	3.7		1.1	2.1	4.1		1.3	1.02	1.76	5.8
	1.9	3.8			2.3	4.3					
1.0	2.0	3.9		1.3	2.5	4.5		0.63	1.02	1.76	5.8
	2.1	4.0			2.5	4.5					
1.1	2.2	4.1									
	2.3	4.2									
1.2	2.4	4.3									
	2.5	4.4									
1.3	2.5	4.5									
	2.5	4.5									
2.5	3.3	5.8		2.5	3.3	5.8	$\varnothing a$	2.5	3.3	5.8	
--	--	--		--	--	--	$s$	0.63	1.02	1.76	