

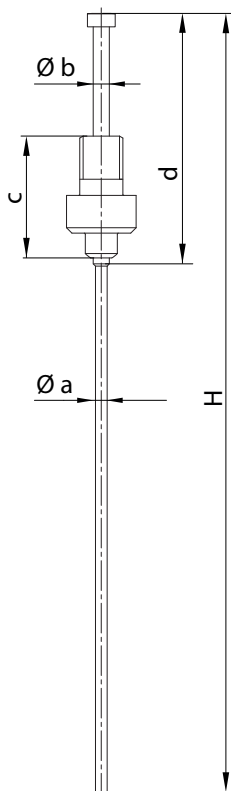

Gruppo spillo - Valve gate pin group



Valve Gate type / Tipo gr.ott.	S20 - S28 - S32				K32	
Nozzle type / Tipo ugello	TF12 - TF17 - TF23 - TD18 - TD22					
Pin group code / Codice gr.spillo	E18330	E20309	E18331	E20310	E18332	E18333
Ø a					Ø 2.5	
Ø b					Ø 3.5	
d	82				57	
c	22.5	37	22.5	37	22.5	
H	280		500		280	500

Valve Gate type / Tipo gr.ott.	S28 - S32				K32	
Nozzle type / Tipo ugello	FN32 - TD30					
Pin group code / Codice gr.spillo	E18334	E20313	E18335	E20314	E18334	E20313
Ø a					Ø 3.3	
Ø b					Ø 3.5	
d					98	
c	22.5	37			22.5	
H	280	500	280	500		

Valve Gate type / Tipo gr.ott.	S60 - K40					
Nozzle type / Tipo ugello	FN46 - DN44					
Pin group code / Codice gr.spillo	E18336			E18337		
Ø a					Ø 5.8	
Ø b					Ø 6	
d					120	
c					30.5	
H	400			600		

Gruppo contrasto - Pressure group

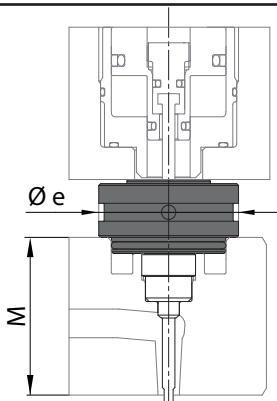

Manifold type / Tipo piastra	C - Conventional / Tradizionale					
Valve gate type / Tipo gr.otturatore	S20		S28 - S32		S60	
Pressure gr. code / Codice gr.contrasto	E20327 - *		E20328 - *		E21474	
Nozzle type / Tipo ugello	TFØ12/17/23 - TDØ18/22		TFØ12/17/23/32 TDØ18/22/30		FNØ46- DN44	
Ø e	Ø 31		Ø 39		Ø 54	
*M	44 - 52 - 62 - TT					

Manifold type / Tipo piastra	B - bolted down					
M	44		52		62	
Ø e	Ø 28	Ø 36	Ø 28	Ø 36	Ø 28	Ø 36
Pressure gr. code / Codice gr.contrasto	E21375	E21466	E21383	E21467	E21384	E21468
Valve gate type / Tipo gr.otturatore	S20 - S28 - S32					
Nozzle type / Tipo ugello	TFØ12/17/23/32 - TDØ18/22/30					

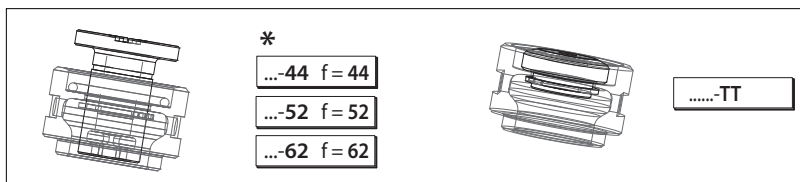

Gruppo otturatore - Valve gate group

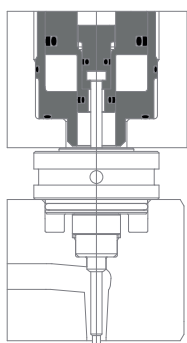

Manifold type / Tipo piastra	C - Conventional / Tradizionale					
Valve gate type / Tipo gr.otturatore	S				K	
Valve gate type / Tipo gr.otturatore	S20 - HY	S28 - PN	S32 - PN	S32 - HY	S60 - PN	K32 - PN K40 - PN
Valve gate gr.code / Codice gr.otturatore	E21105 - *	E21474 - *	E19399 - *	E21487 - *	E18327	E18326 E18329
Nozzle type / Tipo ugello	TFØ12/17/23 TDØ18/22	TFØ12/17/23/32 TDØ18/22/30		FNØ46 DNØ44	TFØ12/17/23/32 TDØ18/22/30	FNØ46 DNØ44
Manifold type / Tipo piastra	B - bolted down					
Valve gate type / Tipo gr.otturatore	S					
Valve gate type / Tipo gr.otturatore	S20 - HY	S28 - PN	S32 - PN	S32 - HY		
Valve gate gr.code / Codice gr.otturatore	E21360	E21492	E21361	E21362		
Nozzle type / Tipo ugello	TFØ12/17/23 TDØ18/22	TFØ12/17/23/32 TDØ18/22/30		TFØ12/17/23/32 TDØ18/22/30		

**K32-PN**

"K" TYPE VALVE GATE GROUP - BORE PISTON 32 - PNEUMATIC
GRUPPO OTTURATORE TIPO "K" - ALESAGGIO PISTONE 32 - PNEUMATICO

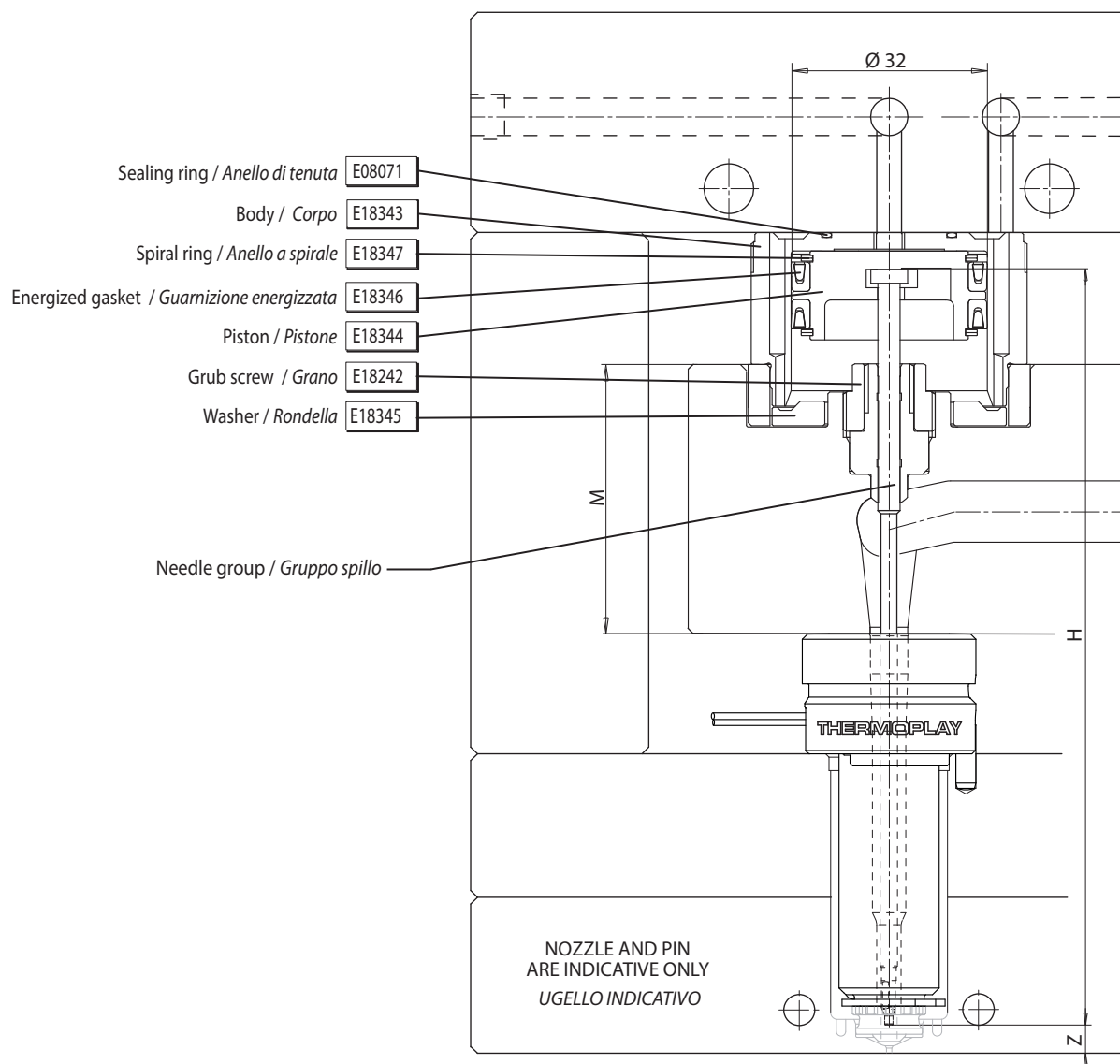

Z = Pin stroke 10.5 mm (for TF3Ø 12 stroke 7 mm) / Corsa spillo 10.5 mm (per TF3Ø 12 corsa 7 mm)

M = Manifold height / Altezza distributore

H = Pin length / Lunghezza spillo

ATTENZIONE!

Si consiglia di non azionare il gruppo otturazione a sistema d'iniezione freddo.

FUNZIONAMENTO PNEUMATICO consigliati 10 bar.

Nelle prove eseguite con stampo non fissato sulla pressa **NON** utilizzare pressioni oltre i 5 bar.

ATTENTION!

Do not activate the shut off group when the injection system is cold

PNEUMATIC OPERATION: 10 bar ADVISED

When testing the injection system on the bench, use 5 bar maximum pressure.

FOR NOZZLES / PER UGELLI

TF3 Ø12 - TF3-TF3B-TF3DSLA-TF3DSLU Ø17-23-32 - TD3 Ø18-22-30



"K" TYPE VALVE GATE GROUP CUTOUT - BORE PISTON 32 - PNEUMATIC
SEDE GRUPPO OTTURATORE TIPO "K" - ALESAGGIO PISTONE 32 - PNEUMATICO

K32-PN

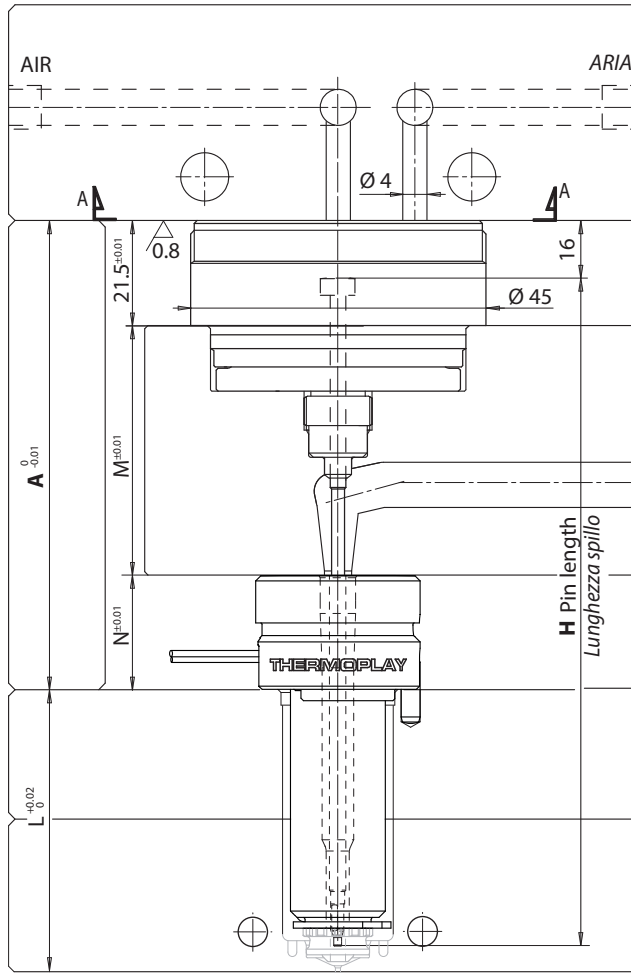
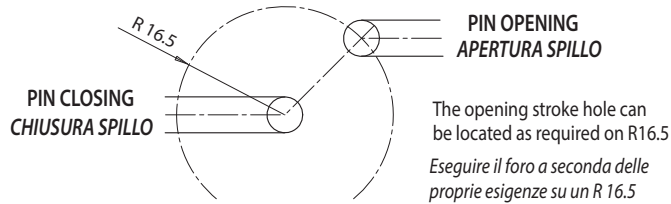

ATTENTION!
Do not activate the shut off group when the injection system is cold
PNEUMATIC OPERATION: 10 bar ADVISED
When testing the injection system on the bench, use 5 bar maximum pressure.

ATTENZIONE!
Si consiglia di non azionare il gruppo otturazione a sistema d'iniezione freddo.
PRESSIONE CONSIGLIATA 10 bar.
Nelle prove eseguite con stampo non fissato sulla pressa **NON** utilizzare pressioni oltre i 5 bar.

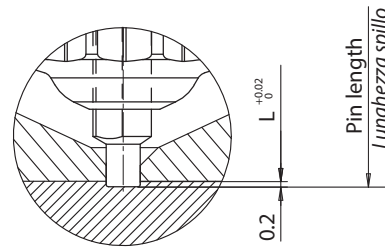

Fastening grub screw with hexagon key (Ø12 DIN 3120 UNI ISO 1174)
Tightening torque 40 Nm
Chiusura grano chiave esagonale (Ø12 DIN 3120 UNI ISO 1174)
Coppia di serraggio 40 Nm

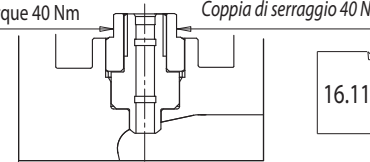

- L** = Nozzle length / Lunghezza ugello
- A** = Spacers thickness / Altezza distanziali
- N** = Nozzle head thickness / Altezza testa ugello
- M** = Manifold height / Altezza distributore

PIN LENGTH ADJUSTMENT WASHER
RONDELLA DI REGOLAZIONE CORSA

Code / Codice	E18345
---------------	--------

* 0.5 = maximum machining to adjust pin length.
* 0.5 = spessore massimo da asportare per regolare la corsa a seconda delle proprie esigenze.

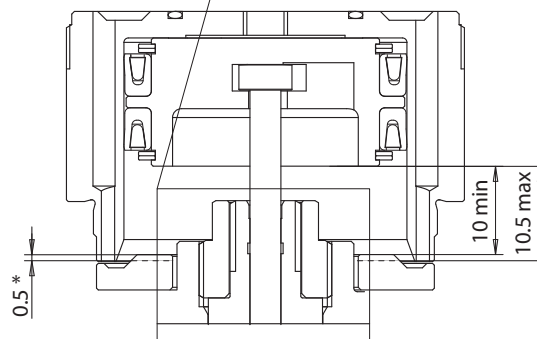

FOR NOZZLES / PER UGELLI

TF3 Ø12 - TF3-TF3B-TF3DSLA-TF3DSLUI Ø17-23-32 - TD3 Ø18-22-30



S20-HY

S28-PN

S32-PN

S32-HY

S60-PN

K32-PN

K40-PN

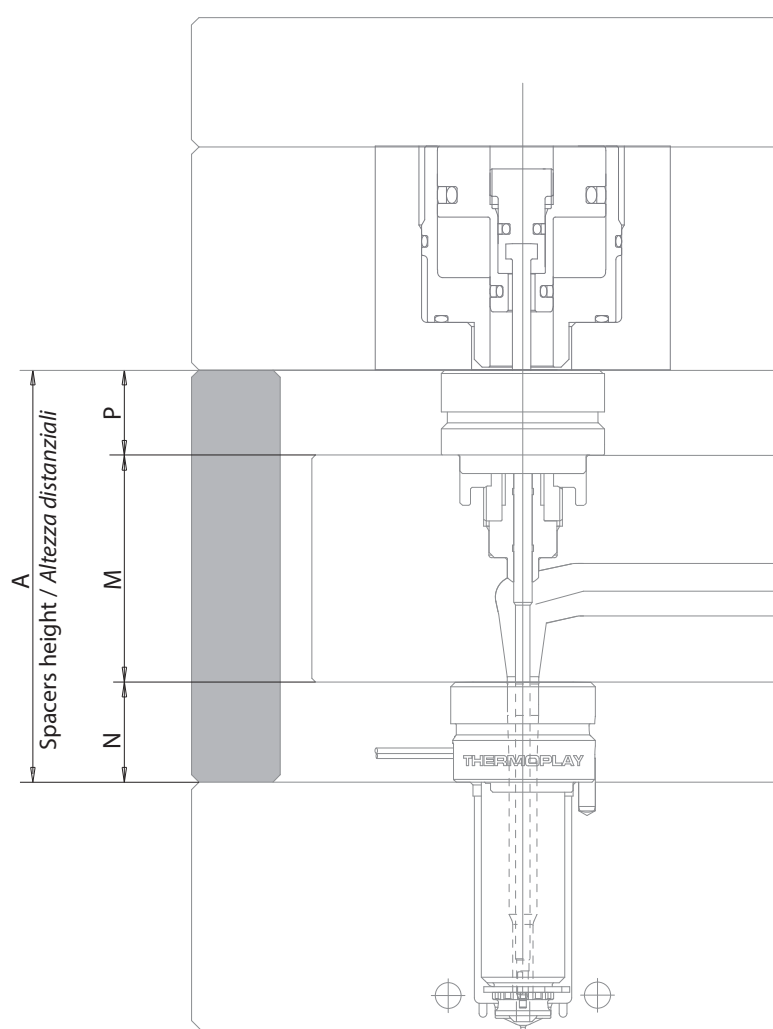

$$A = (N+M+P)+[(N+M+6) \times \Delta t \times K]-0.05 = \text{mm}$$

A	Spacer height / Altezza distanziali									
	Nozzle type / Tipo ugelli									
	TF12	TF17	TF23	TF32	TF46	TD18	TD22	TD30	TD44	
N	13	18	20	20	25	18	20	20	25	
M	Manifold height / Altezza distributore									
	Actuator group / Gruppo otturatore									
	S20HY	S28PN	S32HY	S32PN	S60PN	K32PN	K40PN			
P	16				20		21.5	30.5		
ΔT	Temperature difference between manifold and mold / Differenza di temperatura tra canale caldo e stampo									
k	Coefficient of thermal expansion for steel / Coeficente di dilatazione termica dell'acciaio 0.0000125									
0.05	Theoretical compression value / Valore teorico di chiusura									

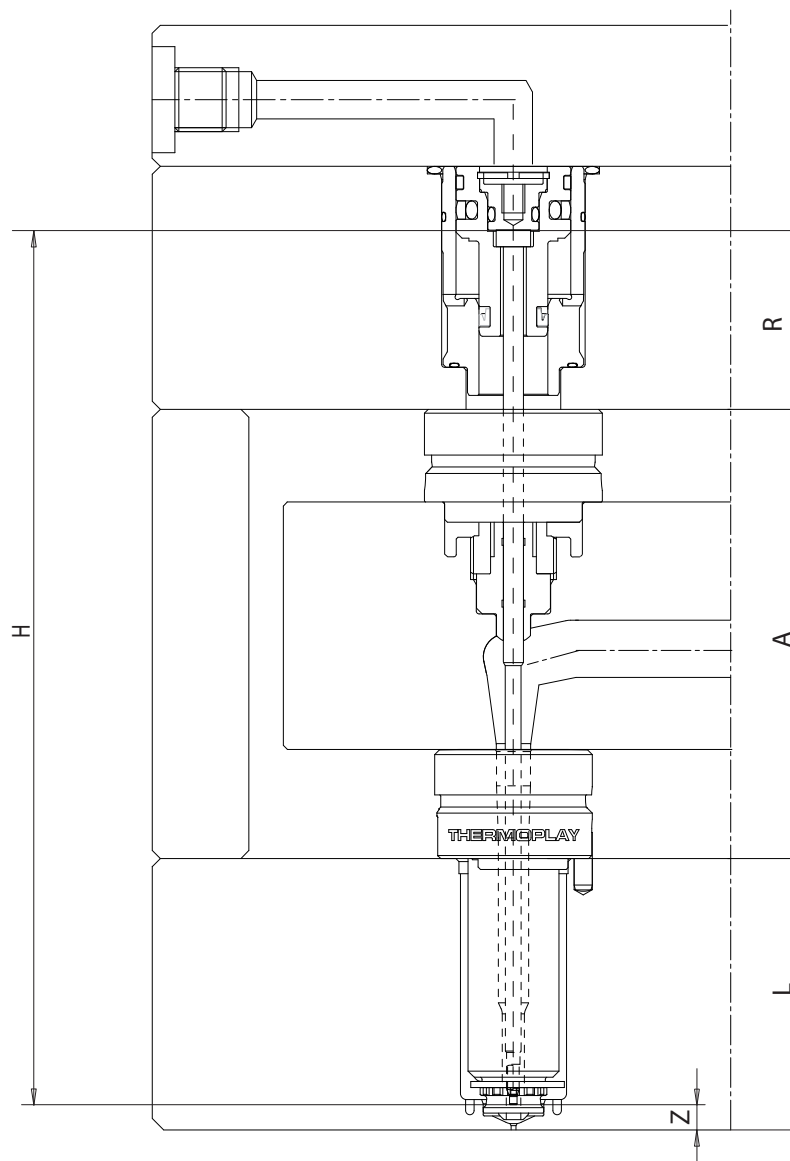

S20-HY

S28-PN

S32-PN

S32-HY

S60-PN

$$H = (L+A+R-Z) - [(L+A+R-Z) \times \Delta t \times k] + n = \text{mm}$$

H	Pin length (cold) / Lunghezza spillo a freddo
----------	---

L	Nozzle length / Lunghezza ugello
----------	----------------------------------

A	Spacer height (including expansion) / Misura dei distanziali comprensiva della dilatazione per il serraggio
----------	---

Valve gate group type / Tipo gruppo otturatore

	S20HY	S28PN	S32HY	S32PN	S60PN
R	31.4	23.95		35.45	
Z	10		16		

Nozzle TIP type / Tipo puntale ugello

	TF3/3B-TF3D/3DSL A all diameters	TD18/22/30/44-3	TF17/23-FN32 - 3DSL U	TF46-3DSL U
n	0.2		0.64	1.76

k	Coefficient of thermal expansion for steel / Coeficiente di dilatazione termica dell'acciaio 0.0000125
----------	--

ΔT	Temperature difference between manifold and mold / Differenza di temperatura tra canale caldo e stampo
-----------	--



K32-PN

K40-PN

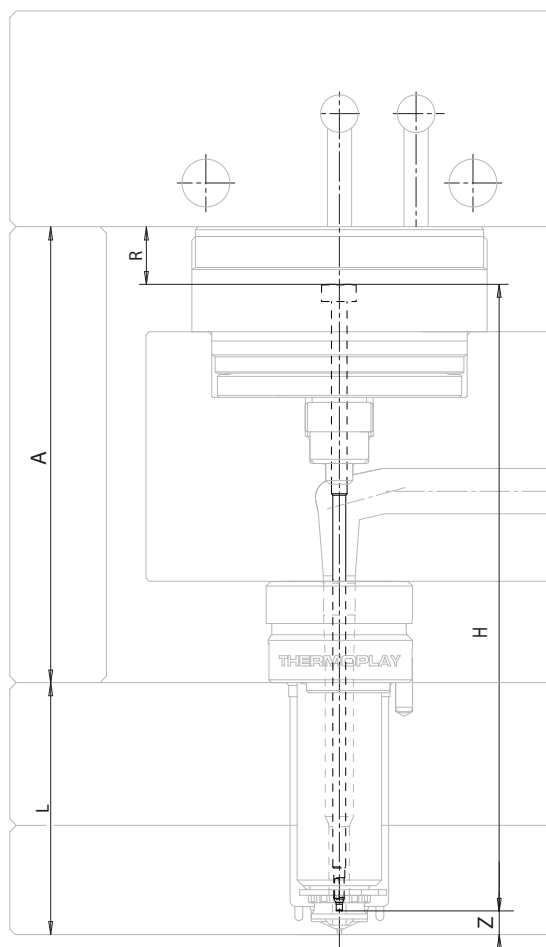

$$H = (L+A-R) - [(L+A-R) \times \Delta t \times k] + N = \text{mm}$$

H	Pin length (cold) / Lunghezza spillo a freddo				
L	Nozzle length / Lunghezza ugello				
A	Spacer height (including expansion) / Misura dei distanziali comprensiva della dilatazione per il serraggio				
Valve gate group type / Tipo gruppo otturatore					
	K32PN		K40PN		
R	16		23		
Z	10		16		
Nozzle TIP type / Tipo puntale ugello					
	TF3/3B-TF3D/3DSL A Ø12-17-23-32-46	TD18/22/30/44-3	TF17/23-3DSL U	TF32-3DSL U	TF44-3DSL U
N	0.2		0.63	1.02	1.76
k	Coefficient of thermal expansion for steel / Coeficente di dilatazione termica dell'acciaio 0.0000125				
ΔT	Temperature difference between manifold and mold / Differenza di temperatura tra canale caldo e stampo				



NOZZLE / UGELLO
TF3 Ø12

INDICATIONS FOR EXECUTION OF PIN PROFILE / INDICAZIONI PER L'ESECUZIONE DEL PROFILO PUNTA SPILLO
(execution customer care - a cura cliente)

CILINDRIC / CILINDRICO

CONICAL / CONICO

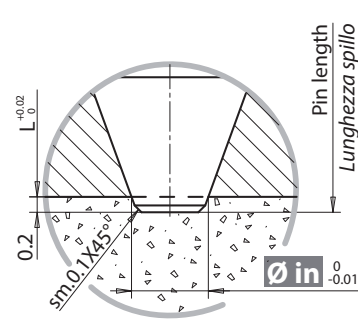
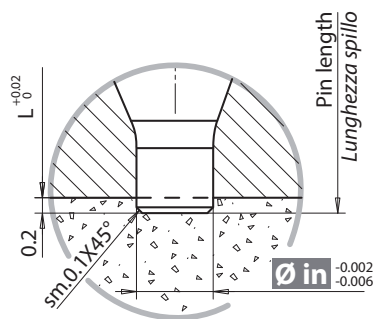
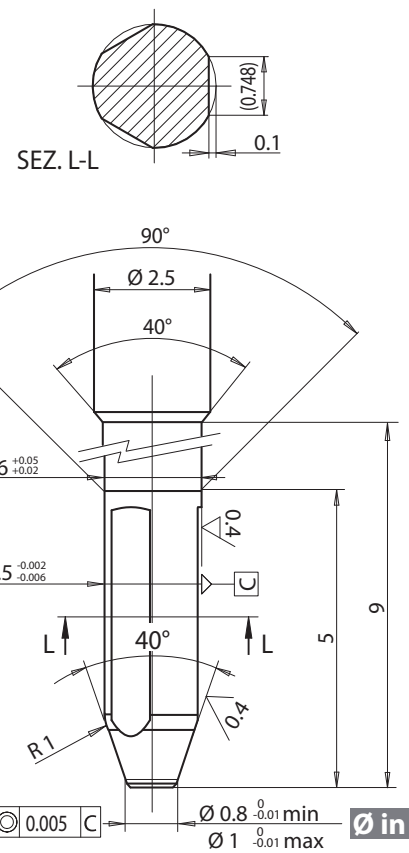
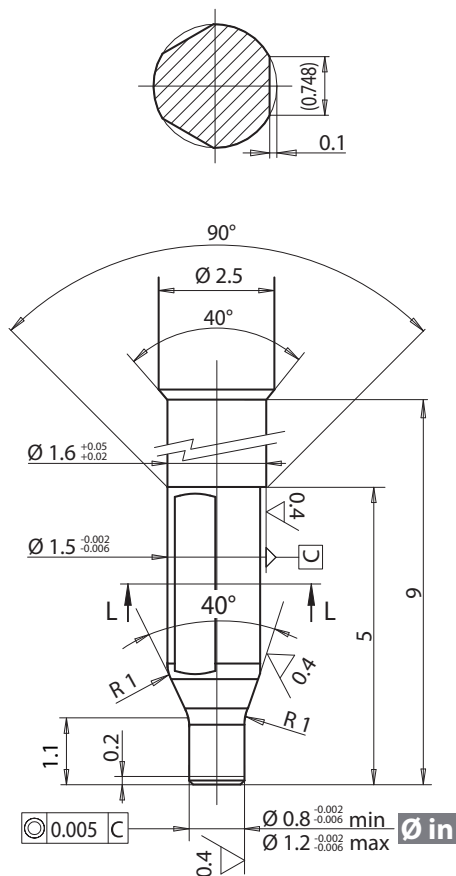

ATTENTION - ATTENZIONE!

With conical shut off, if pin stroke adjustment or length are not correct, damage can occur to steel in the gate area.
Nella chiusura conica l'errata regolazione della corsa dello spillo o della sua lunghezza potrebbero causare danni alla matrice



NOZZLE / UGELLO
TD3 Ø18

INDICATIONS FOR EXECUTION OF PIN PROFILE / INDICAZIONI PER L'ESECUZIONE DEL PROFILO PUNTA SPILLO
(execution customer care - a cura cliente)

CILINDRIC / CILINDRICO

CONICAL / CONICO

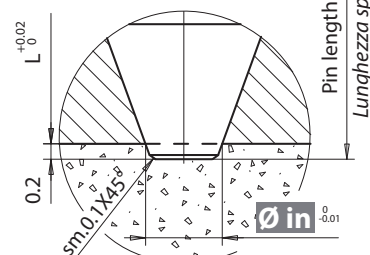
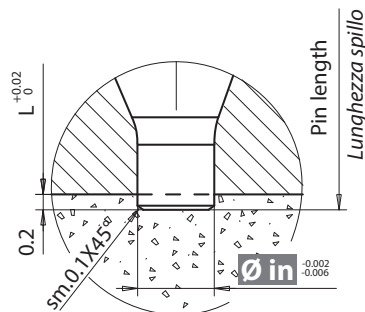
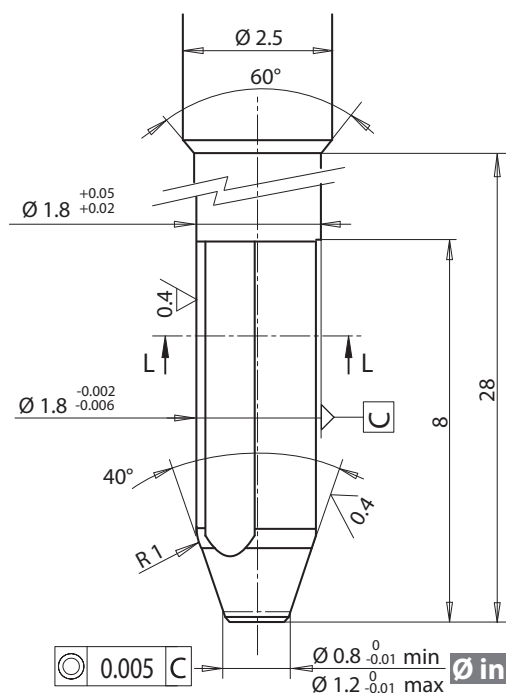
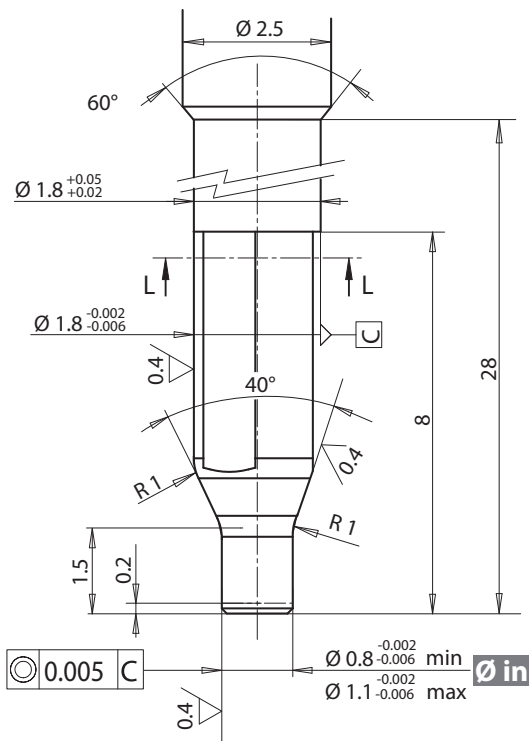
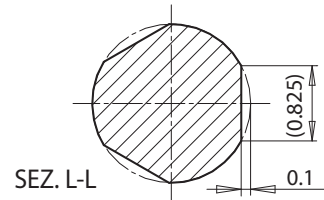
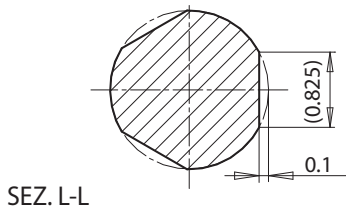

ATTENTION - ATTENZIONE!

With conical shut off, if pin stroke adjustment or length are not correct, damage can occur to steel in the gate area.
*Nella chiusura **conica** l'errata regolazione della corsa dello spillo o della sua lunghezza potrebbero causare danni alla matrice*



NOZZLE / UGELLO
TF3-TF3B-TD3

CILINDRIC / CILINDRICO

(execution customer care - *a cura cliente*)

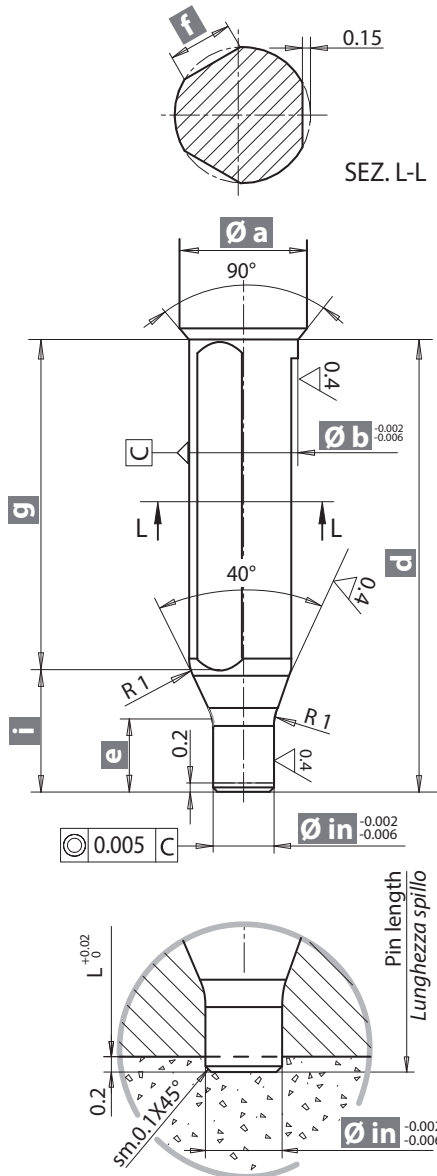

CONICAL / CONICO

(execution customer care - *a cura cliente*)

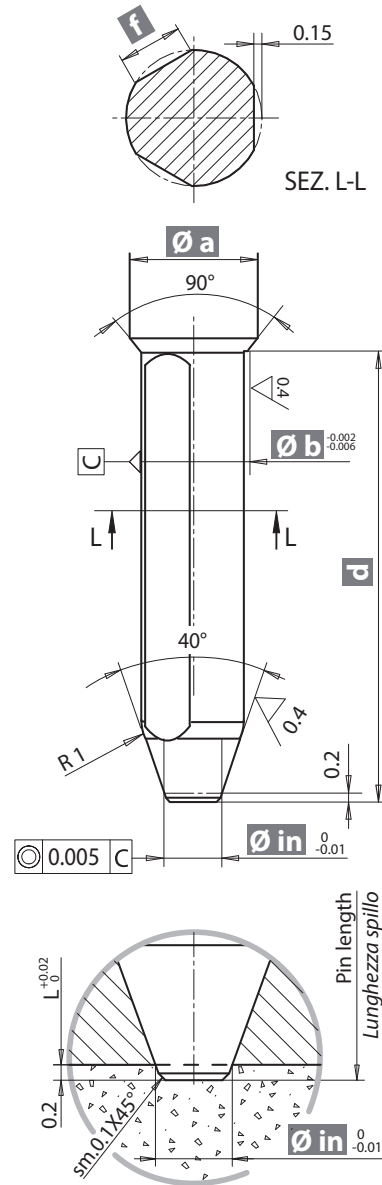

ATTENTION - ATTENZIONE!
With conical shut off, if pin stroke adjustment or length are not correct, damage can occur to the gate area.
Nella chiusura conica l'errata regolazione della corsa dello spillo o della sua lunghezza potrebbero causare danni alla matrice

CILINDRIC / CILINDRICO						
Nozzle type / Tipo ugello						
TF17	TF23	TF32	TF46	TD22	TD30	TD44
0.8	0.8	1.6	3.5	0.8	1.6	3.5
1.8	2	3	5.5	1.3	2	4
2.5	2.5	3.3	5.8	2.5	3.3	5.8
2.4	2.4	3.2	5.7	2.4	3.2	5.7
9	9	9	13	9	9	13
1.5	1.5	1.8	2.2	1.5	1.8	2.2
1.16	1.16	1.35	1.82	1.16	1.35	1.82
-	-	7.7	11.2	-	7.7	11.2
-	-	1.3	1.8	-	1.3	1.8

CONICAL / CONICO						
Nozzle type / Tipo ugello						
TF17	TF23	TF32	TF46	TD22	TD30	TD44
0.8	0.8	1.6	3.5	0.8	1.6	3.5
1.3	1.3	2.5	4.5	1.6	2.5	4.5
2.5	2.5	3.3	5.8	2.5	3.3	5.8
2.4	2.4	3.2	5.7	2.4	3.2	5.7
9	9	9	13	9	9	13
-	-	-	-	-	-	-
1.16	1.16	1.35	1.82	1.16	1.35	1.82
-	-	7.7	11.2	-	7.7	11.2
-	-	1.3	1.8	-	1.3	1.8



NOZZLE / UGELLO
TF3D-TF3DSL A

CILINDRIC / CILINDRICO

(execution customer care - *a cura cliente*)

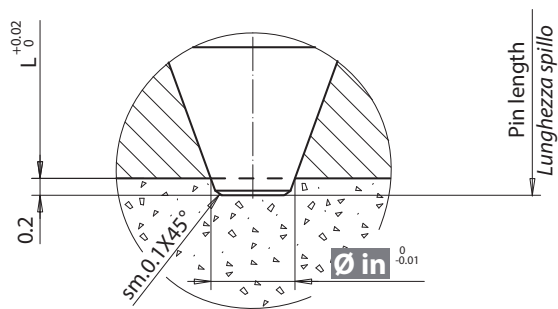
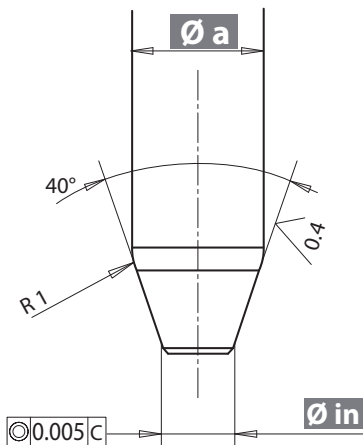

NOZZLE / UGELLO
TF3DSL U

CONICAL / CONICO

(execution customer care - *a cura cliente*)

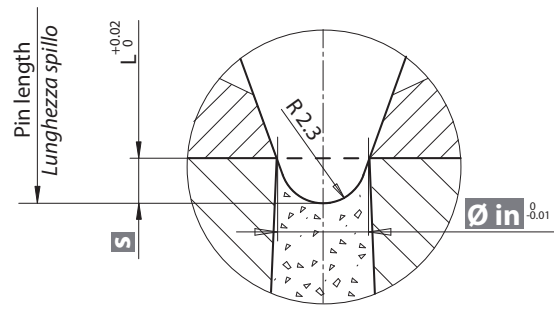
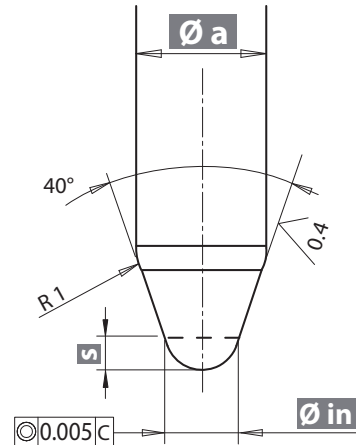

ATTENTION - ATTENZIONE!

With conical shut off, if pin stroke adjustment or length are not correct, damage can occur to steel in the gate area.
Nella chiusura **conica** l'errata regolazione della corsa dello spillo o della sua lunghezza potrebbero causare danni alla matrice

Nozzle type / Tipo ugello							
3D				3DSL A			
TF17	TF23	TF32	TF46	TF17	TF23	TF32	TF46
0.8	1.6	3.5		0.9		1.7	3.5
	1.7	3.6					
0.9	1.8	3.7		1.1		1.9	3.7
	1.9	3.8					
1.0	2.0	3.9		1.3		2.1	3.9
	2.1	4.0					
1.1	2.2	4.1				2.3	4.1
	2.3	4.2					
1.2	2.4	4.3				2.5	4.3
	2.5	4.4					
1.3		4.5					4.5
2.5	3.3	5.8		2.5	3.3	5.8	$\varnothing a$
--	--	--		--	--	--	s

Nozzle type / Tipo ugello			
3DSL U			
TF17	TF23	TF32	TF46
1.3	2.5	4.5	
2.5	3.3	5.8	
0.63	1.02	1.76	